

Joyce Bevel Gear® Jacks (BG) offer higher efficiency and greater speed than other mechanical screw jacks. At the same time, bevel gear jacks with single lead screws (S series) provide the benefits of a self-locking screw – no special brake is required to prevent the jack from lowering under load. Spiral bevel gears increase strength for higher capacities.

Bevel gear jacks are available in 7.5-ton to 100-ton static capacities with either single lead S series or double lead D series lifting screws. Standard jacks have right hand screw threads. Left hand screw threads are available as an option.

Bevel gear jacks also act as miter boxes, making them an ideal choice for multi-jack systems. As many as three output shafts may be specified for mounting motors, limit switches, readout devices and other accessories. See page 195 for an example of a bevel gear jack system. Note that right hand and left hand screw threads are alternated in the layout.

Many options are available and all jack designs can be fitted with protective boots.

Joyce/Dayton can customize bevel gear jacks to meet your requirements.

To properly size jacks, follow the design tips on page 151 and refer to the Thermal Graphs and Column Load charts (pages 152 to 154). Use JAX® software to determine dynamic capacity of jacks or contact Joyce/Dayton.

BEVEL GEAR JACKS



Joyce/Dayton offers Bevel Gear Jacks in several designs including:

- Translating
- Keyed for non-rotation
- Keyed for traveling nut (KFTN)

A guide for ordering is on page 150.

BEVEL GEAR JACKS ORDERING INFORMATION

Instructions: Select a model number from this chart.



Joyce Bevel Gear® Jacks	
BG150S	BG150D
BG250S	BG250D
BG375S	BG375D
BG450S	BG450D





Follow the design tips (pp. 151-154).
Detailed product information (pp. 155-158).
Right hand screw threads standard.

Bevel Gear Jack Rise
Rise is travel expressed in inches and not the actual screw length.

Screw Stops (p. 10) and Boots (p. 170)
Screw stops are optional on Bevel gear jacks. When specified, the closed height of the jack and protection tube length may be increased.

Sample Part Number: **BG150SU2S-12.25-STDX-STDX-STDX-X**

Jack Configuration	
	
U=Upright	I=Inverted

End Conditions			
			
1=T1 (plain end)	2=T2 (load pad)	3=T3 (threaded end)	4=T4 (male clevis)

Jack Design		
		
S=Translating	K=Keyed for Non Rotation	N=Traveling Nut

Encoders and Electronic Limit Switches	
ENCX=Encoder (p. 178)	
ELS2=2 Position Electronic Switch (p. 174)	
ELS4=4 Position Electronic Switch (p. 174)	
ELS6=6 Position Electronic Switch (p. 174)	

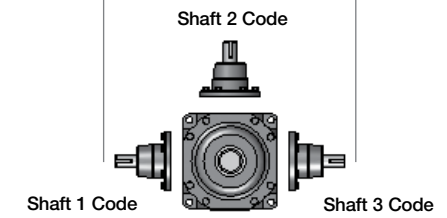







Shaft Codes
Three shaft codes must be specified for each jack. Electronic and mechanical limit switches may be substituted for the shaft code per the tables on this page.
STDX – Standard XXXX – Input shaft not required
When ordering with only one input shaft, it is recommended to order the following configuration: XXXX-STDX-XXXX

Additional Options
X=Standard Jack, no additional options
S=Additional Specification Required (comment as necessary)
Protective Boots pp. 170-172 B=Protective Boot D=Dual Protective Boot
Finishes p. 179 F1=Do not Paint F2=Epoxy Paint F3=Outdoor Paint Process
ACME Screw L=Left Hand Screw
Screw Stops ST0=Extending ST1=Retracting ST2=Both
• Specify as many options as needed

Mechanical Limit Switches (pp. 174-175)

Ordering Example: **LA13**

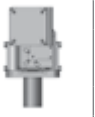
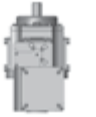
Models		Number of DPDT Switches (see p. 175)	Available Positions							
Model	Code		1	2	3	4	5	6	7	8
LS7-402	LI	NOTE: Will always be 0 for LS7 models								
LS8-402	LA									
LS8-404	LB									
LS9-502	LC									
LS9-503	LD									
LS9-504	LE									
LS9-505	LF									
LS9-506	LG									
LS9-507	LH									

Note: All BG jacks are available with all mounting positions.

BEVEL GEAR JACKS SPECIFICATIONS AND DESIGN TIPS

Model	Dynamic Capacity	Static Load Capacity		Screw		Bevel Gear Ratio	Pinion Turns for 1" Travel	Pinion Torque (In. Lbs.)	Screw Torque	Jack Efficiency	Jack† Cooling Time	Base Weight (Lbs.)	Add for Each Inch of Travel (Lbs.)
		Upright Assembly: screw-in compression/ Inverted Assembly: screw-in tension	Upright Assembly: screw-in tension/ Inverted Assembly: Screw-in compression	Dia.	Pitch/Lead								
BG150-S	Please Use JAX® V2 Software or contact Joyce/Dayton	14,000 lbs.	14,000 lbs.	1 1/2"	.375P STUB ACME	2.69:1	7.18	.059W*	.151W*	38.5%	38 min.	42	.8
BG150-D*					.250P / .500L ACME 2C	2.69:1	5.38	.066W*	.169W*	45.6%	38 min.	42	.8
BG250-S		30,000 lbs.	30,000 lbs.	2 1/2"	.500P ACME 2C	2.15:1	4.31	.111W*	.227W*	34.2%	82 min.	140	2.6
BG250-D*					.375P / .750L ACME 2C	2.15:1	2.87	.133W*	.272W*	42.6%	82 min.	140	2.6
BG375-S		66,000 lbs.	40,000 lbs.	3 3/4"	.666P ACME 2C	3.52:1	5.29	.098W*	.329W*	31.5%	192 min.	230	4.1
BG375-D*					.666P / 1.333L STUB ACME	3.52:1	2.64	.134W*	.448W*	46.0%	192 min.	230	4.1
BG450-S		218,000 lbs.	200,000 lbs.	4 1/2"	.500P ACME 2C	3:1	6	.125W*	.356W*	21.9%	262 min.	650	5.5
BG450-D*					.500P / 1.00L ACME 2C	3:1	3	.154W*	.438W*	35.5%	262 min.	650	5.5

Important Note: *Not self-locking, may lower under load. Brake motors or external locking systems are recommended.

D: Double Lead Screws.

S: Single Lead Screws. These jacks are self-locking.

***W:** Load in Pounds.

Pinion Torque: The torque required to continuously raise a given load.

Screw Torque: The torque required to resist screw rotation (translating jack design) and traveling nut rotation (keyed for traveling nut design).

Lead: The distance traveled axially in one rotation of the lifting screw.

Pitch: The distance from a point on the screw thread to a corresponding point on the next thread, measured axially.

†: Cooling time based on time to cool from 200°F to 70°F (ambient).

Design Tips:

1. A PV (load/velocity) value must be calculated for each application. The continuous running time should not exceed the corresponding T (time) value. Refer to instructions and graphs on pages 152 and 153.
2. Cooling time data on these charts is calculated based on limiting the lifting nut temperature rise from 70°F to 200°F (100° below dropping point of grease).
3. Check single lead versus double lead screws in each case. A double lead screw may be the appropriate choice due to increased efficiency while offering the same performance characteristics.
4. JAX® software is a useful design aid to determine the following:
 - The allowable static compression load for a given rise (or use Column Loading Chart on page 154)
 - The allowable dynamic load for a given rise
 - System horsepower and torque – also see item #5
5. When a direct motor drive is used in a system, consideration must be given to the input starting torque requirements and the motor horsepower will need to be increased accordingly (JAX® software will not do this). Contact Joyce/Dayton for assistance.
6. When selecting multiple bevel gear jacks for an interconnected row or system (page 195) careful attention must be given to the input and output shaft rotations. For example, if the input shaft rotation on the first jack is clockwise, the output shaft(s) on that same jack will rotate counter-clockwise. To insure all jacks raise and lower in unison, alternating jacks must be specified with right and left hand acme screw threads. For example, if you have five jacks interconnected in a straight line and the first jack is right hand, the third and fifth jack will also need to be ordered as right hand and the second and fourth jack will need to be ordered as left hand. Bevel gear jacks are supplied standard with right hand acme screws. To order the left hand acme screw option, add an "L" to the end of your bevel gear jack part number as shown on page 150.
7. Joyce Bevel Gear® "S" Series (single lead) jacks are inherently self-locking. A brake is required for "D" series (double lead) jacks, which may lower under load.
8. Bevel gear jacks are furnished with one input shaft in position #2. Jacks may be ordered with up to three input shafts located at any combination of positions # 1, 2, or 3.
9. Joyce Bevel Gear® jacks are designed for oil bath (EP-90 gear lubricant) or grease operation. The upper bearing is grease lubricated through a fitting on top of the jack. Grease must be applied directly to the lifting screw.
10. Typically jacks are mounted upright with the base plate parallel to the horizon. If the base plate is oriented any other way, contact Joyce/Dayton for lubrication and other instructions.

BEVEL GEAR JACKS APPLICATION INFORMATION AND THERMAL GRAPHS

In many applications, Joyce Bevel Gear® jacks are more efficient and faster than wormgear driven jacks. To determine the suitability of a bevel gear jack for your application, use the steps below to calculate load, travel speed and duty cycle.

Step 1 Determine load in pounds.

Step 2 Determine velocity in feet / minute (fpm).

Step 3 Determine duty cycle in terms of minutes operation / minutes resting (or time on / time off).

Step 4 Calculate PV.
 $PV = (\text{load} \times \text{velocity in fpm}) / 1000$

Step 5 Calculate cooling time (T).
 $T = \text{Cooling time (p. 151)} \times \frac{\text{time on}}{\text{time off}}$

Step 6 Plot the points for PV and T on the appropriate graph (below or on the next page). If the point falls below the line, the application is satisfactory. If it is above the line, recalculate T for the next larger size jack. Each jack size has a different cooling time (p. 151).

Step 7 Calculate horsepower.
 $RPM = \text{Velocity in fpm} \times 12 \times \text{input turns per one-inch travel (from chart on p. 151)}$
 $\text{Horsepower} = \text{Pinion torque (from chart)} \times \text{load} \times RPM$

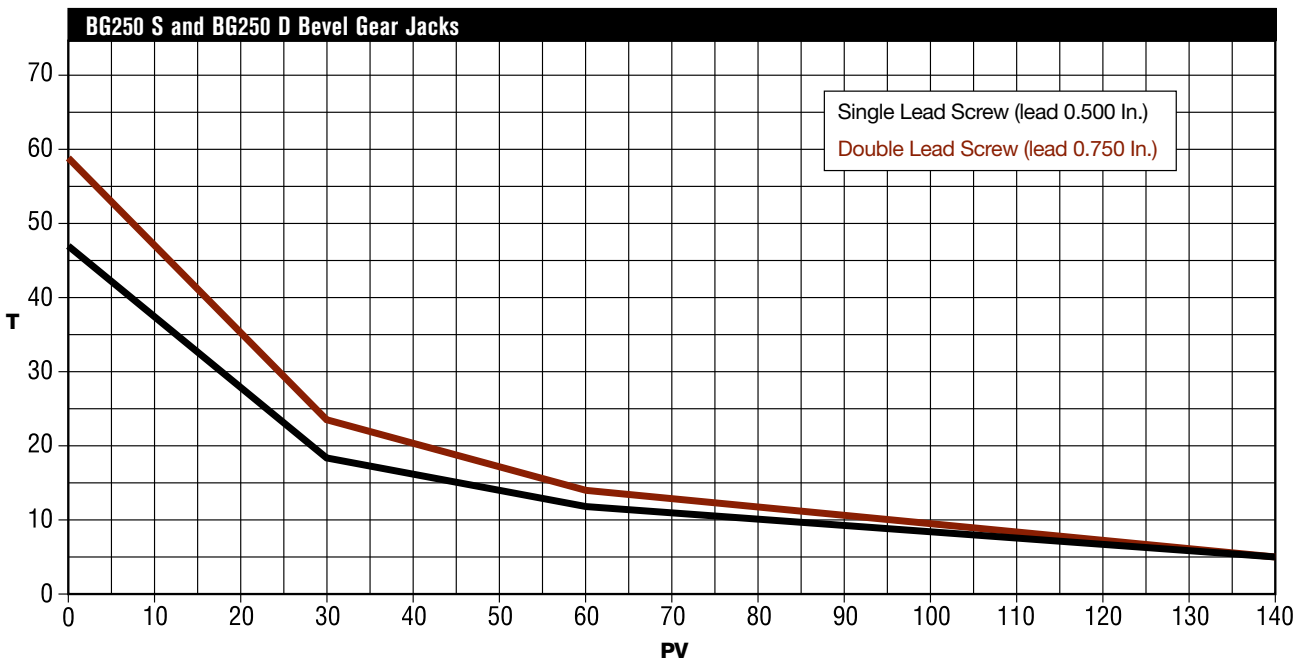
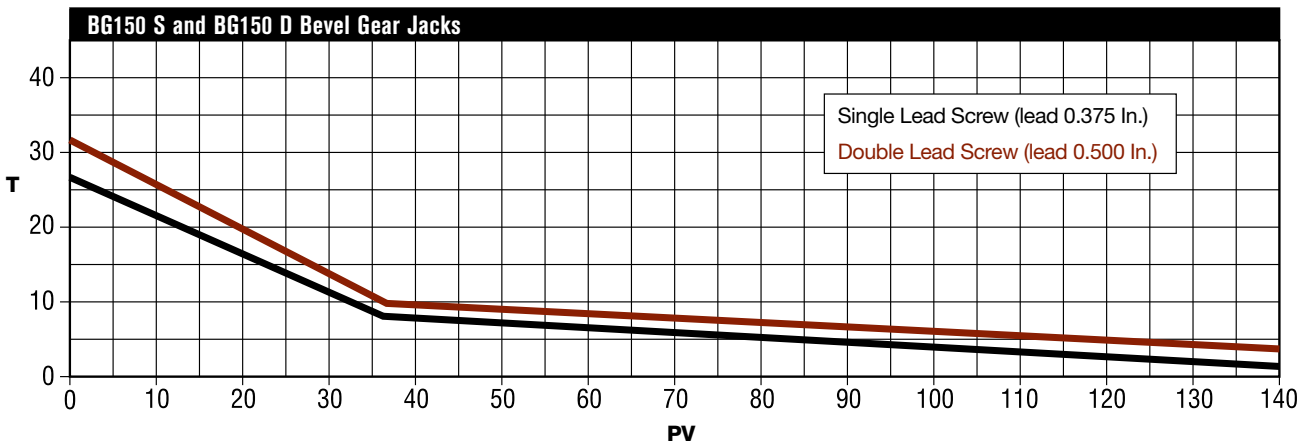

Note: $PV = \frac{\text{load} \times \text{velocity (fpm)}}{1000}$

T = the maximum running time in minutes before a complete cooling time is required.

BEVEL GEAR JACKS EXAMPLE AND THERMAL GRAPHS

Example: A 5000-pound load must be raised 30 inches in 15 seconds. The load remains in position for two minutes. It is then lowered and remains lowered for 30 seconds. The cycle begins again. Determine the appropriate bevel gear jacks and calculate horsepower required.

Step 1 Load = 5000 pounds

Step 2 Velocity = 30 inches in 15 seconds = 10 fpm

Step 3 Duty cycle = Time on / Time off
 Time on = 15 seconds up + 15 seconds down = 30 seconds = 0.5 min
 Time off = 2 minutes up + 30 seconds down = 2 minutes 30 seconds = 2.5 minutes

Step 4 $PV = (5000 \times 10) / 1000 = 50$

Step 5 $T = 38$ (for BG150) $\times (0.5 / 2.5) = 7.6$

Step 6 The point for PV, 50. and T, 7.6 falls below the line for BG 150 D and above the line for BG 150S, therefore BG 150 D is appropriate. (reference BG150 chart on p. 152)

Step 7 $RPM = 10 \times 12 \times 5.38 = 645.6$
 Horsepower = $(.066 \times 5000 \times 646) / 63,025 = 3.38$

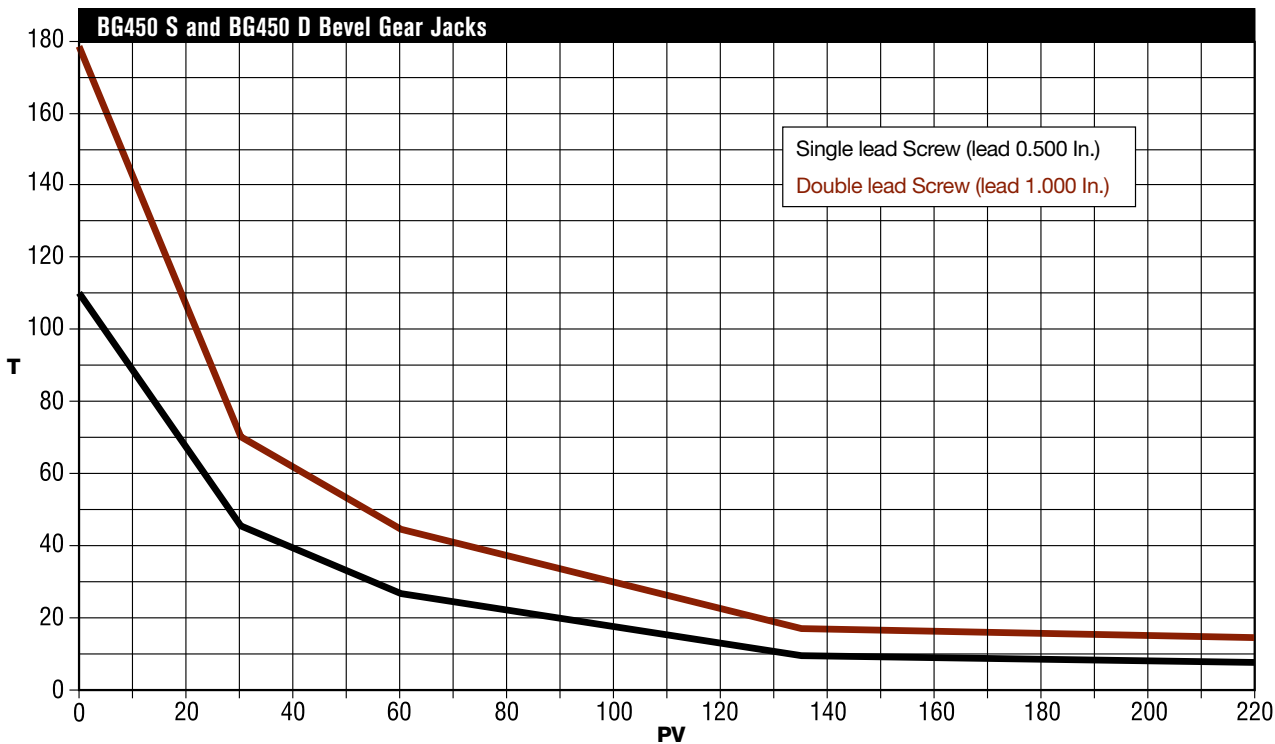
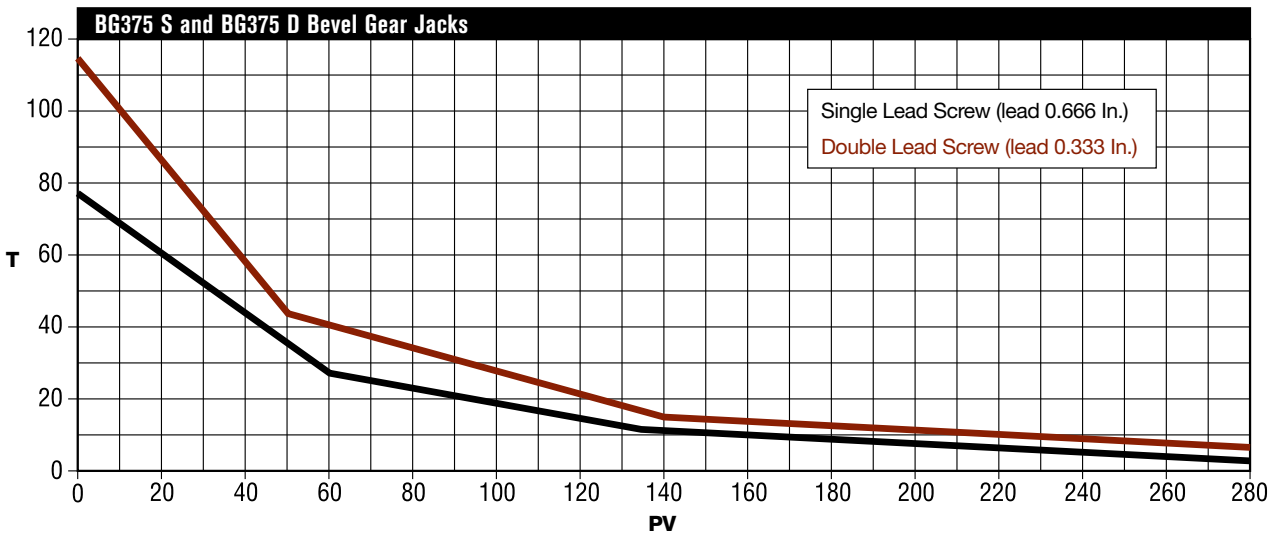

Note: $PV = \frac{\text{load} \times \text{velocity (fpm)}}{1000}$

T = the maximum running time in minutes before a complete cooling time is required.

BEVEL GEAR JACKS COLUMN LOADING

Joyce Bevel Gear® Jacks Column Loading Chart

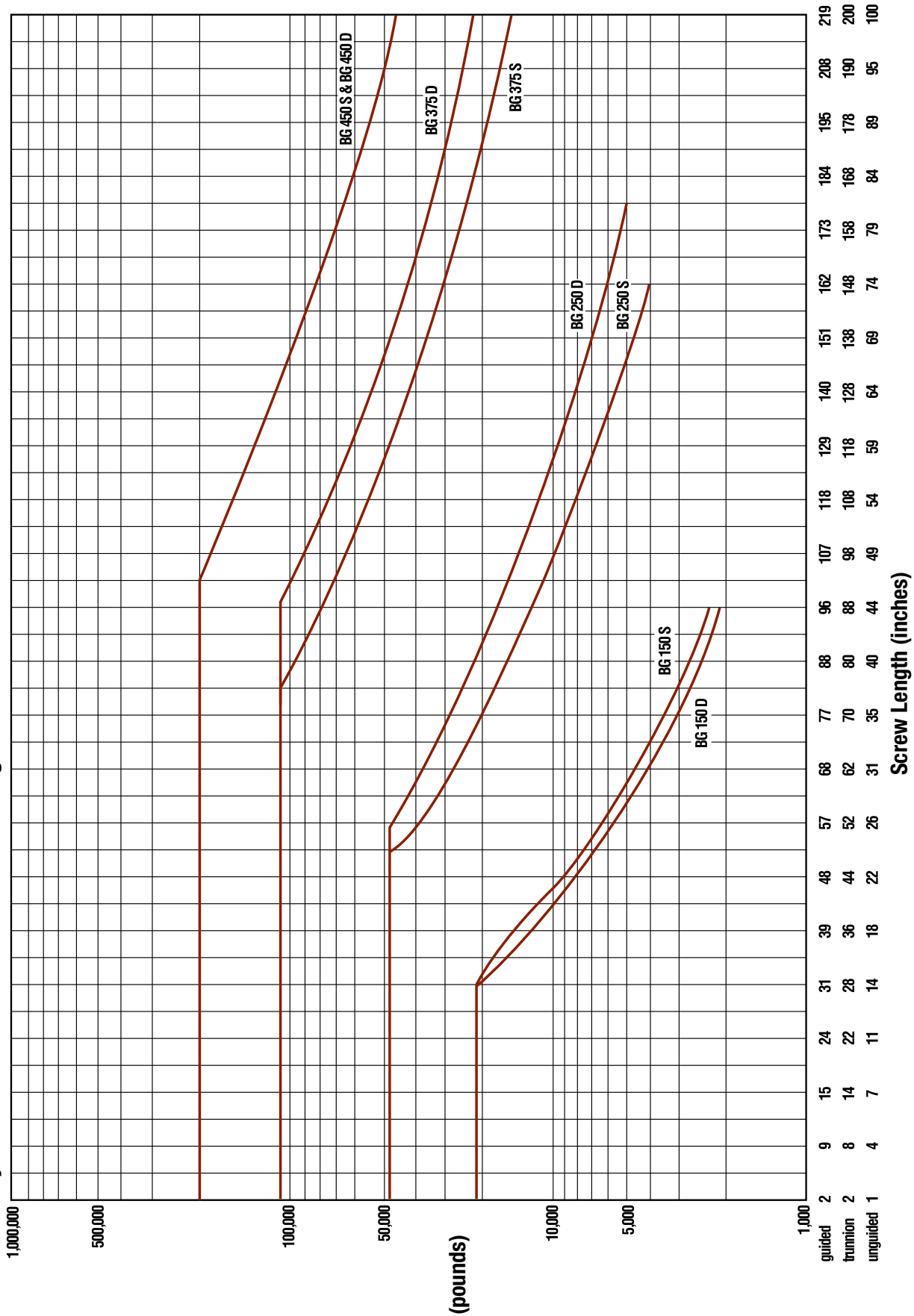

This chart includes a 2:1 Factor-of-Safety based on the Euler-Johnson equation for column loading (Oberg, Erik et al: Machinery's Handbook, 24th Edition. c. 1992 Industrial Press Inc.)
The horizontal portion of each line represents the jack's maximum static capacity.

BEVEL GEAR JACKS

BG 150 - 1 1/2" SCREW

Upright

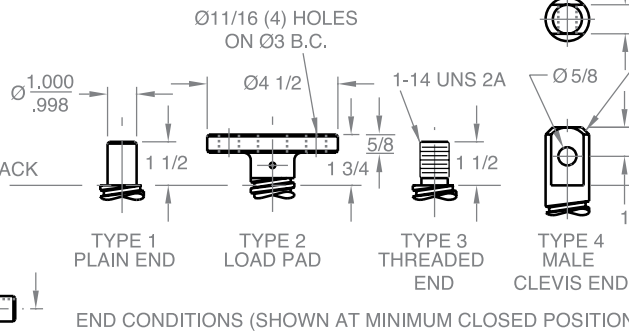
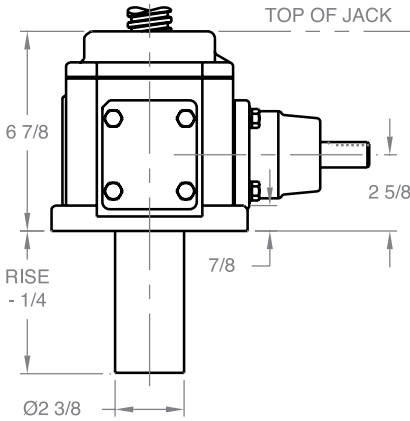

Upright keyed

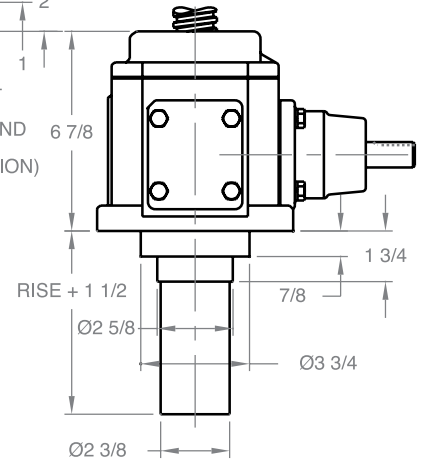

Upright traveling nut

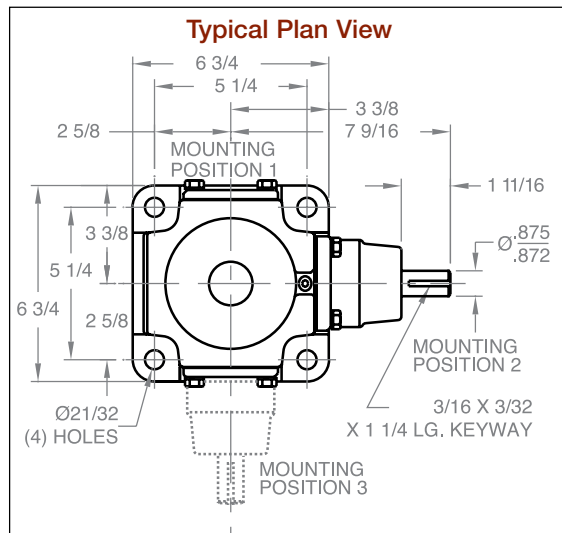
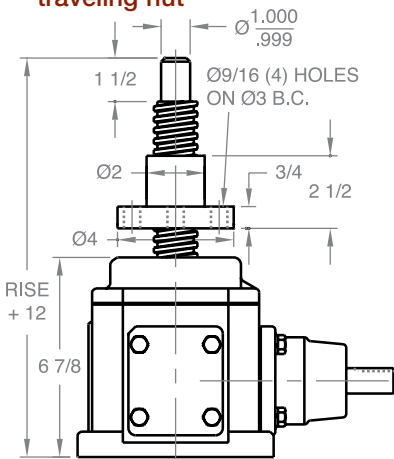

Inverted traveling nut

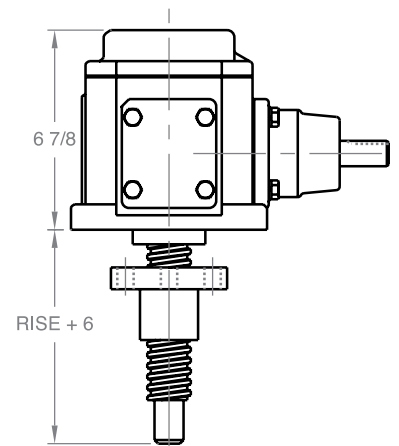

Inverted

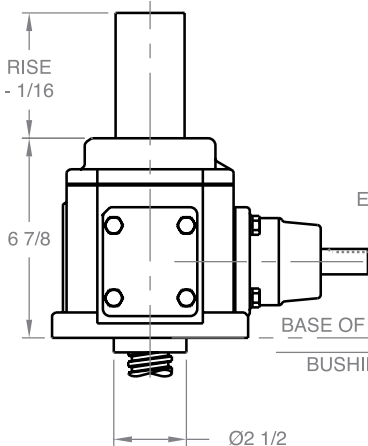

END CONDITIONS (SHOWN AT MINIMUM CLOSED POSITION)
(DOES NOT APPLY TO INVERTED KEYED JACK)

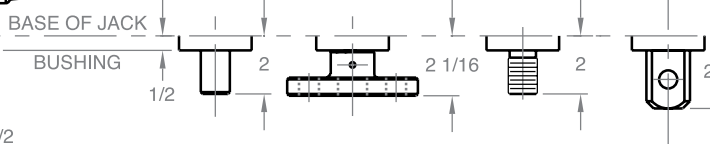

Inverted keyed

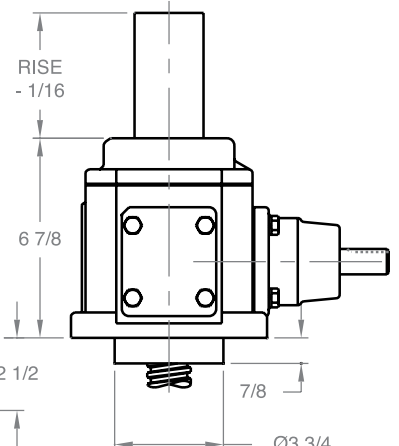

Note: Drawings are artist's conception — not for certification; dimensions are subject to change without notice.

BEVEL GEAR JACKS

BG 250 - 2 1/2" SCREW

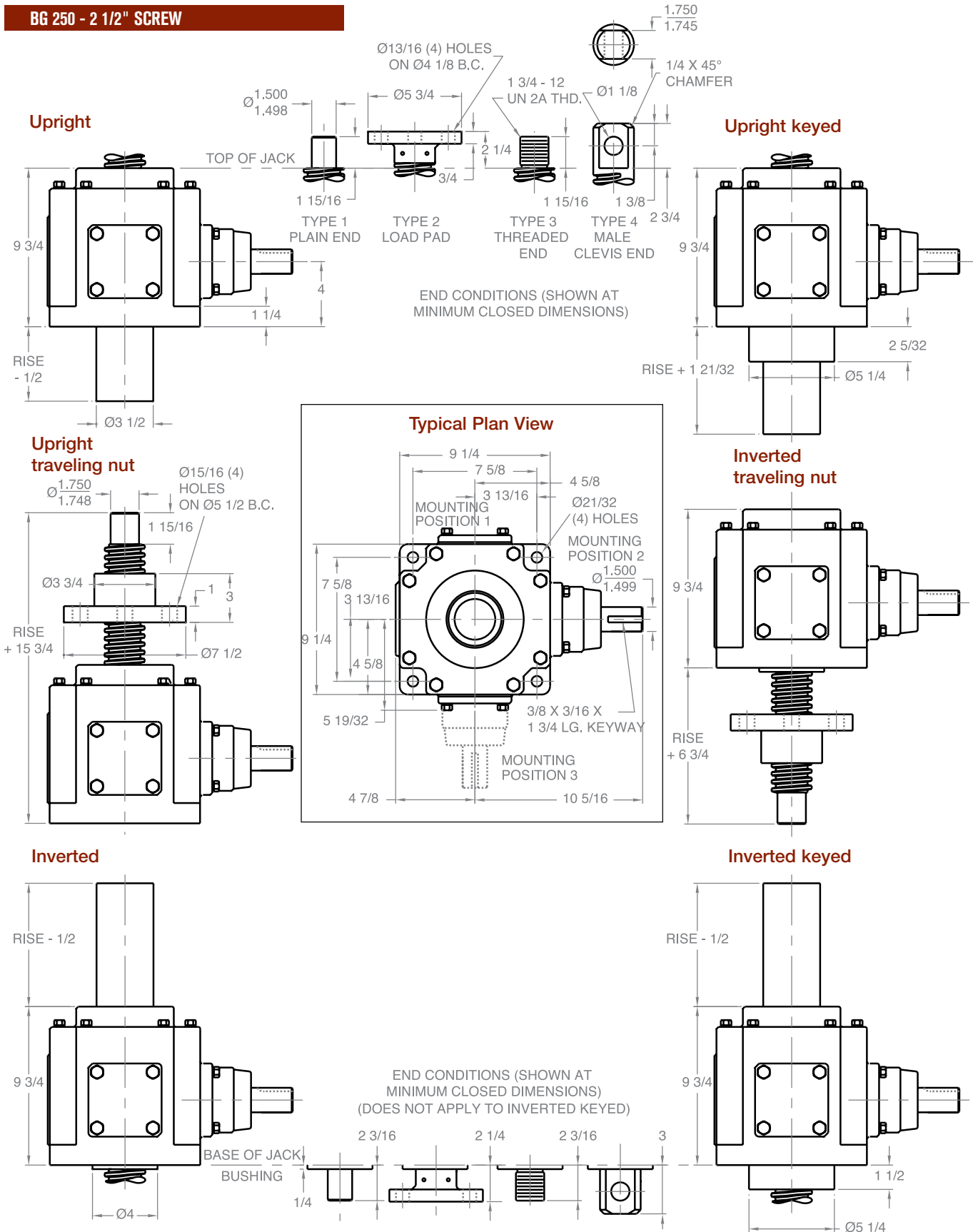

Note: Drawings are artist's conception — not for certification; dimensions are subject to change without notice.

BEVEL GEAR JACKS

BG 375 - 3 3/4" SCREW

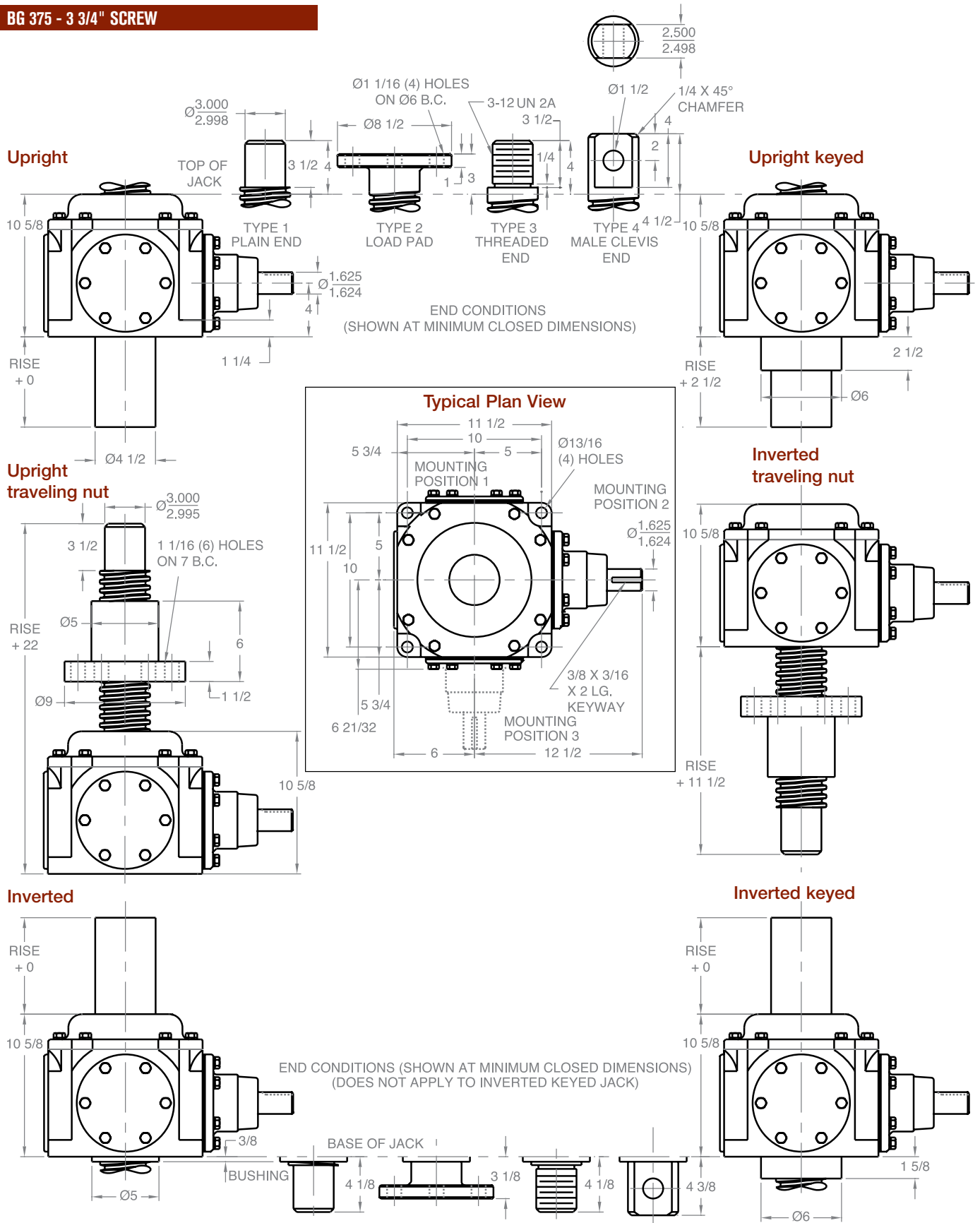

Note: Drawings are artist's conception — not for certification; dimensions are subject to change without notice.

