

Joyce electric cylinders are designed to lift and precisely position loads in industrial environments where protection of the lifting screw mechanism is critical and low maintenance is desired. Requiring only electric power, Joyce electric cylinders may also be used in place of hydraulic cylinders, eliminating the cost and potential for leaks associated with hydraulic systems.

Electric cylinders use the same drive housings offered on our rugged machine screw and ball screw jacks. They are available in 2.5-ton to 20-ton capacities. Electric cylinders can achieve speeds up to 546 inches per minute and raise loads up to 100 inches. Complete dynamic speed/load ratings and maximum rise information can be viewed on our quick reference charts (pages 125 to 129). Both acme screw (ECA) and ball screw (ECB) models are designed to operate at the charted capacities under both tension and compression loading.

Joyce Electric Cylinder Features and Benefits:

- Ground and hard-chrome plated inner cylinder tube resists harsh contaminants while providing smooth cylinder translation.
- Dual lip tube seals retain lubrication while preventing dirt and grime from entering the internal cavity and contaminating the lifting screw.
- Enamel outer finish provides a durable coating for external surfaces.
- Rigid cylinder tube guide bearings provide resistance to buckling (external guides are required when side loads are present).
- Alloy steel input shafts riding on tapered roller bearings provide proper wormgear alignment for increased service life.
- Spring-loaded input shaft seals prevent the loss of lubrication.

Joyce/Dayton can customize electric cylinders to meet your specifications.



ELECTRIC CYLINDERS

Electric Cylinder Operation:

The input shaft (worm) shaft rotates a wormgear, which in turn rotates the lifting screw. As the lifting screw rotates, it forces the lifting nut (fixed to the cylinder tube) to translate, thus extending or retracting the cylinder tube. For proper operation, the load being lifted must be restrained from rotation.

Joyce/Dayton offers Electric Cylinders in several models including:

- Standard
- Motor mount
- ComDRIVE®

A guide for ordering is on pages 120 and 121.

ELECTRIC CYLINDERS ORDERING INFORMATION

Instructions: Select a model number from this chart.

2.5-Ton ACME Screw	2.5-Ton Ball Screw	3-Ton ACME Screw	3-Ton Ball Screw	5-Ton ACME Screw	5-Ton Ball Screw	10-Ton ACME Screw	10-Ton Ball Screw	20-Ton ACME Screw	20-Ton Ball Screw
ECAL242.5	ECBL62.5 ECBL122.5 ECBL242.5	ECAL63 ECAL123 ECAL243	ECBL63 ECBL123 ECBL243	ECAL65 ECAL245	ECBL65 ECBL125 ECBL245	ECAL810 ECAL2410	ECBL810 ECBL2410	ECAL820 ECAL2420	ECBL820 ECBL2420
ECAH62.5 ECAH122.5 ECAH242.5	ECBM62.5 ECBH62.5		ECBH63 ECBH123 ECBH243	ECAM65 ECAM125 ECAM245	ECBM65 ECBM125 ECBM245	ECAM810 ECAM2410	ECBM810 ECBM2410	ECAM820 ECAM2420	
				ECAH65 ECAH125 ECAH245	ECBH65 ECBH125 ECBH245	ECAH810 ECAH2410	ECBH810 ECBH2410	ECAH820 ECAH2420	

Important Note: Electric Cylinders that are $\geq 30\%$ efficient may lower under load. Brake motors or external locking systems are required. Detailed information about each electric cylinder model is available on pages 125-134.

Sample Part Number: **ECAL654C-18.5-STDX-STDX-X**

Tube End Conditions

3 (threaded end) 4 (male clevis)

5 (female clevis) 6 (female clevis with pin)

Cylinder Rise

Rise is travel expressed in inches and not the actual tube length. The allowable travel for each unit is listed in the Quick Reference section. Allowable lengths differ for vertical and horizontal mounting.

Left Side Shaft Code

(see below)

XXXX=Remove
STDX=Standard

For optional shaft codes, see page 121.

Right Side Shaft Code

(see below)

XXXX=Remove
STDX=Standard

For optional shaft codes, see page 121.

Additional Options

X=Standard, no additional options

S=Additional Specification Required (comment as necessary)

Finishes p. 179
F1=Do Not Paint
F2=Epoxy Paint
F3=Outdoor Paint Process

Motor Options
M1=Less Motor
M2=Brake Motor
M3=Single Phase Motor (120VAC)
M4=50Hz Motor

Grease/Seals
H1=High Temperature Operation
H2=Food Grade Grease

• Specify as many options as needed

Base Designs

F=Flange Base C=Clevis Base R=Rotated Clevis Base

ELECTRIC CYLINDERS SHAFT CODES

Instructions: Select the appropriate shaft codes for both right and left hand shafts. One shaft code must be specified for each side of the electric cylinder.

Hand Wheels (p. 177)

HW04=4" dia
 HW06=6" dia
 HW08=8" dia
 HW10=10" dia
 HW12=12" dia

Not recommended for cylinders that are ≥ 30% efficient.



Geared Potentiometers (p. 176)

POTA=0-10V (IP65)
 POTB=4-20MA (IP65)
 POTC=0-10V w/2 switches*
 POTD=4-20MA w/2 switches*

*Optional IP65 rating available.



Mechanical Counters (p. 177)

CNT0=0.001" Increments

Note: Contact Joyce/Dayton for availability and options.



Encoders and Electronic Limit Switches

ENCX=Encoder (p. 178)
 ELS2=2 Position Electronic Switch (p. 174)
 ELS4=4 Position Electronic Switch (p. 174)
 ELS6=6 Position Electronic Switch (p. 174)



ComDrive Reducers (pp. 125-134)

Ordering Example: **P2AC** — Motor code from chart at right

Mounting Positions	P1	P2	P3	P4	Ratio
Left Side Shaft Positions					5:1 Code A
Right Side Shaft Positions					7.5:1 Code B
					10:1 Code C

Motors

Size	Code
1/4 HP	K
1/3 HP	A
1/2 HP	B
3/4 HP	C
1 HP	D
1-1/2 HP	E
2 HP	F
3 HP	L
5 HP	G

Motor Mounts (p. 185)

Ordering Example: **MMA A** — Motor code from chart at left

MMA=56C
 MMB=140TC
 MMC=180TC
 MMD=210TC

Standard motor adapters are aluminum.



All standard motors are 3-phase, 208-230/460 VAC or 230/460 VAC. Specify the appropriate motor size from the chart above. Refer to the "Additional Options" chart on the preceding page as needed. Brake motors are required for electric cylinders that are more than 30% efficient. Contact Joyce/Dayton options that are not listed.

Mechanical Limit Switches (pp. 174-175)

Ordering Example: **LA13**

Models		Number of DPDT Switches (see p. 175)	Available Positions		
Model	Code		1	3	5
LS7-402	LI	NOTE: Will always be 0 for LS7 models			
LS8-402	LA				
LS8-404	LB				
LS9-502	LC				
LS9-503	LD				
LS9-504	LE				
LS9-505	LF				
LS9-506	LG				
LS9-507	LH				

* 2.5, 3, 5, 10, and 20 Ton Electric Cylinders are available with positions #1, #3, and #5

To order additional options, use these part numbers (p. 124)

Female Clevis Bracket
 FCB-30
 FCB-100
 FCB-200

Clevis Pin w/ retaining rings
 CP-30
 CP-100
 CP-200

Female Rod Clevis
 FRC-30
 FRC-100
 FRC-200

ELECTRIC CYLINDERS MODELS



Standard

The Joyce standard electric cylinder is intended for applications where the customer provides their own drive mechanism. To determine capacity, input torque, and turns-per-inch use the specification chart on page 123. This design can also be used where one or more electric cylinders are being driven by one common drive motor or in combination with the motor mount (direct drive) or ComDRIVE® models listed below.

Example part number:

ECAL635C-15.00-STDX-HW08-X

Acme screw (ECA), low lead (L), 6:1 gear ratio (6), 3-ton capacity (3), female clevis (5), clevis base (C), 15 inches rise (15), standard input shaft left hand side of jack (STDX), 8" diameter hand wheel right side of jack (HW08), no additional options (X).



Motor Mount (direct drive)

Joyce motor mount electric cylinders are intended for higher speed applications. Motor mount models can be used in conjunction with one or more of the standard electric cylinders shown above. To determine lifting speed and capacity, view "direct drive" models shown on the quick reference charts (pages 125-129). Standard motors are 3-phase, 230/460 VAC, 60 Hz, and 1750 RPM. For additional motor information, see page 185.

Example part number:

ECAM24104R-9.50-STDX-MMBE-F2

Acme screw (ECA), medium lead (M), 24:1 gear ratio (24), 10-ton capacity (10), male clevis (4), rotated clevis base (R), 9 1/2 inches rise (9.50), standard input shaft left hand side of jack (STDX), 145TC motor mount (MMB) with 1 1/2 HP motor (E) on right hand side, epoxy paint (F2).



ComDRIVE®

Joyce ComDRIVE® models include a right angle gearmotor mounted to the right or left side of the standard model. ComDRIVES are intended for applications requiring heavy lifting capacities at speeds up to 34 inches per minute (acme screw) and 104 inches per minute (ball screw). ComDRIVE models can be used in conjunction with one or more of the standard electric cylinders shown above. To determine lifting speeds and capacity, refer to the charts on pages 125-129.

Example part number:

ECAH8206F-52.25-P1CL-ENCX-M3

Acme screw (ECA), high lead (H), 8:1 gear ratio (8), 20-ton capacity (20), female clevis with pin (6), flange base (F), 52 1/4 inches rise (52.25), 10:1 reducer with a 3 horsepower motor mounted to left hand side of jack (P1CL), encoder on right side of jack (ENCX), single phase motor (M3).

ELECTRIC CYLINDERS SPECIFICATIONS

Model	Static Capacity	Screw Diameter	Thread Pitch/Lead	Wormgear Ratio	Worm Shaft Turns for 1" Travel	Tare Torque (Inch Lbs.)	Starting Torque (Inch Lbs.)	Operating Torque (Inch Lbs.)	Translating Tube Torque (Inch Lbs.)	Base Weight	Weight per Inch Travel		
ECAL242.5	2.5 ton	1	.25 pitch ACME 2C	24:1	96	6	.018W*	.010W* @500 RPM	.098W*	24	1.5		
ECAH62.5				6:1	12	8	.056W*	.040W* @500 RPM	.140W*				
ECAH122.5			.25 pitch .5 lead ACME 2C	12:1	24	7	.035W*	.023W* @500 RPM		.045W*			
ECAH242.5				24:1	48	6	.025W*	.014W* @500 RPM					
ECBL62.5			0.25 lead ball	6:1	24	8	.017W*	.013W* @500 RPM	.089W*				
ECBL122.5				12:1	48	7	.010W*	.008W* @500 RPM					
ECBL242.5			.5 lead ball	24:1	96	6	.008W*	.005W* @500 RPM	.177W*				
ECBM62.5				6:1	12	8	.033W*	.026W* @500 RPM					
ECBH62.5	1.0 lead ball	6:1	6	8	.065W*	.051W* @500 RPM							
ECAL63	3 ton	1 1/4	.25 pitch ACME 2C	6:1	24	9	.048W*	.033W* @500 RPM	.114W*	26	1.9		
ECAL123				12:1	48	8	.030W*	.018W* @500 RPM					
ECAL243				24:1	96	7	.021W*	.011W* @500 RPM					
ECBL63				6:1	30	9	.013W*	.011W* @500 RPM					
ECBL123		1 3/20	.2 lead ball	12:1	60	8	.008W*	.006W* @500 RPM	.036W*	32	1.9		
ECBL243				24:1	120	7	.006W*	.004W* @500 RPM					
ECBH63		1 1/16	.625 lead ball	6:1	9.6	9	.041W*	.032W* @500 RPM	.111W*	32	1.8		
ECAH123				12:1	19.2	8	.025W*	.018W* @500 RPM					
ECBH243	24:1			38.4	7	.018W*	.011W* @500 RPM						
ECAL65	5 ton			1 1/2	.25 pitch ACME 2C	6:1	24	15				.057W*	.039W* @300 RPM
ECAL245		24:1	96			12	.026W*	.014W* @300 RPM					
ECAM65		.375 pitch STUB ACME	6:1			16	15	.065W*	.045W* @300 RPM	.151W*			
ECAM125			12:1			32	13	.041W*	.025W* @300 RPM				
ECAM245			24:1		64	12	.030W*	.016W* @300 RPM					
ECAH65			.25 pitch .5 lead ACME 2C		6:1	12	15	.073W*	.051W* @300 RPM		.171W*		
ECAH125		12:1			24	13	.046W*	.029W* @300 RPM					
ECAH245		24:1			48	12	.033W*	.018W* @300 RPM					
ECBL65		.474 lead ball			6:1	12.66	15	.032W*	.025W* @300 RPM	.084W*			
ECBL125			12:1		25.33	13	.020W*	.014W* @300 RPM					
ECBL245			24:1		50.66	12	.015W*	.009W* @300 RPM					
ECBM65			1.0 lead ball		6:1	6	15	.067W*	.052W* @300 RPM		.177W*		
ECBM125		12:1			12	13	.042W*	.030W* @300 RPM					
ECBM245		24:1			24	12	.031W*	.018W* @300 RPM					
ECBH65		1.875 lead ball			6:1	3.2	15	.125W*	.098W* @300 RPM	.332W*			
ECBH125			12:1		6.4	13	.079W*	.055W* @300 RPM					
ECBH245			24:1		12.8	12	.057W*	.034W* @300 RPM					
ECAL810			10 ton		2	.25 pitch ACME 2C	8:1	32	30		.052W*	.036W* @200 RPM	.162W*
ECAL2410		24:1					96	25	.026W*	.016W* @200 RPM			
ECAM810		.5 pitch ACME 2C				8:1	16	30	.061W*	.044W* @200 RPM	.195W*		
ECAM2410						24:1	48	25	.031W*	.019W* @200 RPM			
ECAH810		.333 pitch .666 lead ACME 2C				8:1	12	30	.070W*	.051W* @200 RPM	.228W*		
ECAH2410						24:1	36	25	.035W*	.022W* @200 RPM			
ECBL810		.474 lead ball			8:1	16.88	30	.023W*	.019W* @200 RPM	.084W*			
ECBL2410	24:1			50.66	25	.012W*	.008W* @200 RPM						
ECBM810	1.0 lead ball	8:1		8	30	.049W*	.040W* @200 RPM	.172W*					
ECBM2410		24:1		24	25	.024W*	.017W* @200 RPM						
ECBH810	1.875 lead ball	8:1		4.27	30	.091W*	.074W* @200 RPM	.332W*					
ECBH2410		24:1		12.8	25	.045W*	.031W* @200 RPM						
ECAL820	20 ton	2 1/2	.25 pitch ACME 2C	8:1	32	60	.066W*	.044W* @200 RPM	.194W*	124	4.9		
ECAL2420				24:1	96	40	.035W*	.019W* @200 RPM					
ECAM820			.5 pitch ACME 2C	8:1	16	60	.075W*	.052W* @200 RPM	.227W*				
ECAM2420				24:1	48	40	.039W*	.022W* @200 RPM					
ECAH820		.375 pitch .75 lead ACME 2C	8:1	10.67	60	.088W*	.062W* @200 RPM	.273W*					
ECAH2420			24:1	32	40	.046W*	.027W* @200 RPM						
ECBL820		.5 lead ball	8:1	16	60	.026W*	.020W* @200 RPM	.089W*					
ECBL2420			24:1	48	40	.014W*	.009W* @200 RPM						

Important Note: Electric cylinders that are ≥ 30% are not self-locking. Brake motors or external locking systems are required.

*W: Load in pounds.

Tare Torque: Initial torque to overcome seal and normal assembly drag. This value must be added to starting torque or operating torque values.

Starting Torque: Torque value required to start moving a given load (dissipates to operating torque values once the load begins moving).

Operating Torque: Torque required to continuously raise a given load at the input RPM listed.

Translating Tube Torque: Torque required to resist tube rotation.

Lead: The distance traveled axially in one rotation of the lifting screw.

Pitch: The distance from a point on a screw thread to a corresponding point on the next thread, measured axially.

ELECTRIC CYLINDERS CLEVIS AND BRACKET

Female Rod Clevis

A female rod clevis end is included for type 5 and type 6 end conditions. They are also available as options.

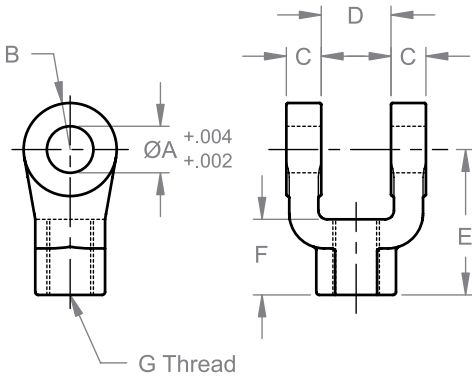

Cylinder Capacity	Part Number	Dimensions (Inches)							Load Capacity (Lbs.)
		ØA	B	C	D	E	F	G	
2.5 & 3	FRC-30	3/4	3/4	5/8	1 1/4	2 3/8	1 1/8	3/4-16	11,200
5 & 10	FRC-100	1	1	3/4	1 1/2	3 1/8	1 5/8	1-14	19,500
20	FRC-200	1 3/8	1 3/8	1	2	4 1/8	2	1 1/4-12	33,500

Clevis Pin with Retaining Rings

A clevis pin with retaining rings is included on type 6 end conditions. They are also available as options.

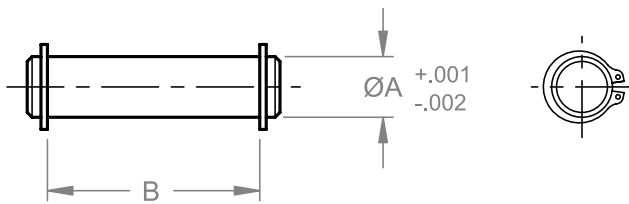

Cylinder Capacity	Part Number	Dimensions (Inches)		Load Capacity (Lbs.)
		ØA	B	
2.5 & 3	CP-30	3/4	2 5/8	19,300
5 & 10	CP-100	1	3 1/8	34,300
20	CP-200	1 3/8	4 1/8	65,000

Female Clevis Bracket

Female clevis brackets are available as options.

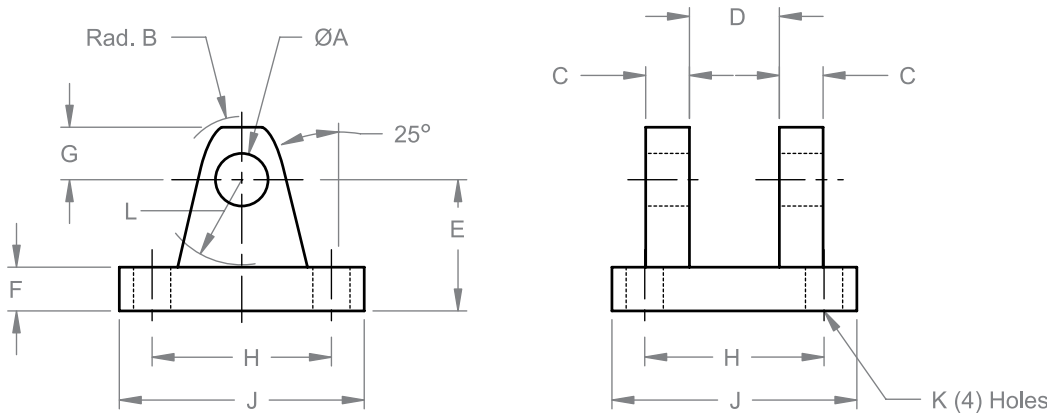

Cylinder Capacity	Part Number	Dimensions (Inches)											Load Capacity (Lbs.)
		ØA	B	C	D	E	F	G	H	J	K	L	
2.5 & 3	FCB-30	3/4	29/32	5/8	1 1/4	1 7/8	5/8	3/4	3.82	5	17/32	1 3/16	14,000
5 & 10	FCB-100	1	1 1/4	3/4	1 1/2	2 1/4	3/4	1	4.95	6 1/2	21/32	1 1/2	19,200
20	FCB-200	1 3/8	1 21/32	1	2	3	7/8	1 3/8	5.73	7 1/2	21/32	2	33,500

Note: Drawings are artist's conception — not for certification; dimensions are subject to change without notice.

ELECTRIC CYLINDERS QUICK REFERENCE

Use the following charts to select the electric cylinder that best fits your application. Refer to drawings on page 130. Contact Joyce/Dayton with questions regarding the proper selection of electric cylinders.

2.5-Ton Thrust Capacity Electric Cylinders											
Model	Max Static Capacity (tons)	Screw Lead (in)	Linear Speed (in/min)	External Gearbox Ratio	Estimated Efficiency	Max Dynamic Load at HP (lbs)					
						.33HP	.5HP	.75HP	1HP	1.5HP	2HP
ACME Screw											
ECAL242.5	2.5	0.250	1.76	10	14%	5,000					
ECAL242.5	2.5	0.250	2.38	7.5	15%	5,000					
ECAH242.5	2.5	0.500	3.53	10	20%	5,000					
ECAH242.5	2.5	0.500	4.76	7.5	21%	5,000					
ECAH122.5	2.5	0.500	7.06	10	25%	4,234	5,000				
ECAH122.5	2.5	0.500	9.52	7.5	26%	3,219	5,000				
ECAH62.5	2.5	0.500	14.12	10	28%	2,374	3,701	5,000			
ECAL242.5	2.5	0.250	18.23	Direct drive	21%	756	1,543				
ECAH62.5	2.5	0.500	19.04	7.5	29%	1,787	2,811	4,317			
ECAH62.5	2.5	0.500	27.78	5	30%	1,213	1,946	3,025			
ECAH242.5	2.5	0.500	36.46	Direct drive	30%	525	1,072				
ECAH122.5	2.5	0.500	72.92	Direct drive	33%		555	1,010	1,464	2,373	
ECAH62.5	2.5	0.500	145.83	Direct drive	36%			512	754	1,238	1,723
Ball Screw											
ECBL242.5	2.5	0.250	1.76	10	30%	5,000					
ECBL242.5	2.5	0.250	2.38	7.5	32%	5,000					
ECBL122.5	2.5	0.250	3.53	10	38%	5,000					
ECBL122.5	2.5	0.250	4.76	7.5	40%	5,000					
ECBL62.5	2.5	0.250	7.06	10	43%	5,000					
ECBL62.5	2.5	0.250	9.52	7.5	45%	5,000					
ECBL62.5	2.5	0.250	13.89	5	47%	3,752	5,000				
ECBL242.5	2.5	0.250	18.23	Direct drive	46%	1,624	3,315				
ECBM62.5	2.5	0.500	19.04	7.5	45%	2,763	4,347	5,000			
ECBM62.5	2.5	0.500	27.78	5	47%	1,876	3,010	4,678	5,000		
ECBL122.5	2.5	0.250	36.46	Direct drive	52%	762	1,718	3,123	4,528	5,000	
ECBH62.5	2.5	1.000	38.08	7.5	45%	1,381	2,173	3,338			
ECBH62.5	2.5	1.000	55.56	5	47%	938	1,505	2,339	3,247		
ECBL62.5	2.5	0.250	72.92	Direct drive	55%		833	1,582	2,331	3,830	5,000
ECBM62.5	2.5	0.500	145.83	Direct drive	55%			791	1,166	1,915	2,664
ECBH62.5	2.5	1.000	291.67	Direct drive	55%				583	957	1,332

2.5-Ton Electric Cylinders			
	Maximum Rise		Cylinder Tube Torque
	Vertical Operation	Horizontal Operation	(in*lb) Per Pound Thrust
ACME Screw			
ECAL	28"	21"	.098
ECAH	28"	21"	.139
Ball Screw			
ECBL	41"	31"	.045
ECBM	44"	33"	.089
ECBH	41"	31"	.178

Selection Guidelines:

- Select the model most closely matching your desired load and speed requirements. The chart is sorted by static capacity, then screw type (ACME or ball), then travel speed.
- To determine the maximum rise for the model selected, see maximum rise chart above.
- L, M, and H in the model numbers designate low, medium, or high screw leads.
- ECA models are not suitable for duty cycles greater than 25%.
- All models with efficiencies >30% require a brake motor.**
- Models with efficiencies ≤30% are self-locking in the absence of vibration. A brake motor is required if vibration is present or faster stopping times are desired.
- Loads and speeds shown assume use of a 1750 rpm 3ph AC induction motor.
- Cylinder tube torque per pound thrust is the means to calculate how much torque must be resisted at the mounting locations of the cylinder. To calculate torque (in*lb), multiply the value in the chart times the load in pounds.
- When ordering cylinders with a ComDRIVE reducer the listed part number should specify the proper 4 letter ComDRIVE shaft code from page 121. Units with a "direct drive" listing should specify the proper 4 letter motor mount code listed on page 121.

ELECTRIC CYLINDERS QUICK REFERENCE

Use the following charts to select the electric cylinder that best fits your application. Refer to drawings on page 131. Contact Joyce/Dayton with questions regarding the proper selection of electric cylinders.

3-Ton Thrust Capacity Electric Cylinders											
Model	Max Static Capacity (tons)	Screw Lead (in)	Linear Speed (in/min)	External Gearbox Ratio	Estimated Efficiency	Max Dynamic Load at HP (lbs)					
						.33HP	.5HP	.75HP	1HP	1.5HP	2HP
ACME Screw											
ECAL243	3	0.250	1.76	10	12%	6,000					
ECAL243	3	0.250	2.38	7.5	13%	6,000					
ECAL123	3	0.250	3.53	10	15%	5,183	6,000				
ECAL123	3	0.250	4.76	7.5	16%	3,926	6,000				
ECAL63	3	0.250	7.06	10	17%	2,906	4,547	6,000			
ECAL63	3	0.250	9.52	7.5	18%	2,179	3,446	5,310			
ECAL63	3	0.250	13.89	5	19%	1,468	2,375	3,710	5,162		
ECAL243	3	0.250	18.23	Direct drive	18%		1,215				
ECAL63	3	0.250	72.92	Direct drive	22%				899	1,499	2,098
Ball Screw											
ECBL243	3	0.200	1.41	10	30%	6,000					
ECBL243	3	0.200	1.90	7.5	32%	6,000					
ECBL123	3	0.200	2.82	10	38%	6,000					
ECBL123	3	0.200	3.81	7.5	40%	6,000					
ECBH243	3	0.625	4.41	10	30%	6,000					
ECBL63	3	0.200	5.65	10	43%	6,000					
ECBH243	3	0.625	5.95	7.5	32%	6,000					
ECBL63	3	0.200	7.62	7.5	45%	6,000					
ECBH123	3	0.625	8.82	10	38%	5,183	6,000				
ECBL63	3	0.200	11.11	5	47%	4,587	6,000				
ECBH123	3	0.625	11.90	7.5	40%	3,926	6,000				
ECBL243	3	0.200	14.58	Direct drive	46%	1,686	3,798				
ECBH63	3	0.625	17.65	10	43%	2,906	4,547	6,000			
ECBH63	3	0.625	23.80	7.5	45%	2,179	3,446	5,310			
ECBL123	3	0.200	29.17	Direct drive	52%	758	1,952	3,709	5,465	6,000	
ECBH63	3	0.625	34.72	5	47%	1,468	2,375	3,710	5,162		
ECBH243	3	0.625	45.57	Direct drive	46%		1,215				
ECBL63	3	0.200	58.33	Direct drive	55%		937	1,874	2,810	4,683	6,000
ECBH123	3	0.625	91.15	Direct drive	52%		625	1,187	1,749	2,873	
ECBH63	3	0.625	182.29	Direct drive	55%				899	1,499	2,098

3-Ton Electric Cylinders			
	Maximum Rise		Cylinder Tube Torque
	Vertical Operation	Horizontal Operation	(in*lb) Per Pound Thrust
ACME Screw			
ECAL	48"	36"	.113
Ball Screw			
ECBL	56"	42"	.036
ECBH	46"	34"	.111

Selection Guidelines:

- Select the model most closely matching your desired load and speed requirements. The charts are sorted by static capacity, then screw type (ACME or ball), then travel speed.
- To determine the maximum rise for the model selected, see maximum rise charts above and to the right.
- L, M, and H in the model numbers designate low, medium, or high screw leads.
- ECA models are not suitable for duty cycles greater than 25%.
- All models with efficiencies >30% require a brake motor.**
- Models with efficiencies ≤30% are self-locking in the absence of vibration. A brake motor is required if vibration is present or faster stopping times are desired.
- Loads and speeds shown assume use of a 1750 rpm 3ph AC induction motor.
- Cylinder tube torque per pound thrust is the means to calculate how much torque must be resisted at the mounting locations of the cylinder. To calculate torque (in*lb), multiply the value in the chart times the load in pounds.
- When ordering cylinders with a ComDRIVE the reducer listed in the part number should specify the proper ComDRIVE 4 letter shaft code from page 121. Units with a "direct drive" listing should specify the proper 4 letter motor mount code listed on page 121.

ELECTRIC CYLINDERS QUICK REFERENCE

Use the following charts to select the electric cylinder that best fits your application. Refer to drawings on page 132. Contact Joyce/Dayton with questions regarding the proper selection of electric cylinders.

5-Ton Thrust Capacity Electric Cylinders											
Model	Max Static Capacity (tons)	Screw Lead (in)	Linear Speed (in/min)	External Gearbox Ratio	Estimated Efficiency	Max Dynamic Load at HP (lbs)					
						.33HP	.5HP	.75HP	1HP	1.5HP	2HP
ACME Screw											
ECAL245	5	0.250	1.76	10	11%	6,895	10,000				
ECAM245	5	0.375	2.65	10	14%	5,891	9,330	10,000			
ECAH245	5	0.500	3.53	10	16%	5,193	8,224	10,000			
ECAM125	5	0.375	5.29	10	17%	3,661	5,822	9,000	10,000		
ECAH125	5	0.500	7.06	10	20%	3,227	5,132	7,933	10,000		
ECAM65	5	0.375	10.59	10	19%	2,031	3,257	5,059	7,022		
ECAH65	5	0.500	14.12	10	23%	1,790	2,871	4,460	6,189		
ECAL245	5	0.250	18.23	Direct drive	16%			1,471			
ECAM65	5	0.375	20.83	5	21%		1,634	2,635	3,723	5,768	7,813
ECAM245	5	0.375	27.34	Direct drive	21%			1,257			
ECAH65	5	0.500	27.78	5	25%		1,441	2,322	3,282	5,085	6,887
ECAH245	5	0.500	36.46	Direct drive	24%			1,108			
ECAM125	5	0.375	54.69	Direct drive	23%				1,085	1,935	
ECAL65	5	0.250	72.92	Direct drive	19%					1,144	1,672
ECAM65	5	0.375	109.38	Direct drive	25%						1,429
ECAH65	5	0.500	145.83	Direct drive	29%						1,259
											2,055
Ball Screw											
ECBL245	5	0.474	3.34	10	30%	10,000					
ECBL125	5	0.474	6.69	10	38%	6,441	10,000				
ECBM245	5	1.000	7.06	10	30%	4,910	7,775	10,000			
ECBH245	5	1.875	13.24	10	30%	2,618	4,147	6,394			
ECBL65	5	0.474	13.37	10	43%	3,572	5,729	8,900	10,000		
ECBM125	5	1.000	14.12	10	38%	3,051	4,852	7,500	10,000		
ECBH125	5	1.875	26.47	10	38%	1,627	2,588	4,000	5,537		
ECBL65	5	0.474	26.32	5	47%	1,678	2,875	4,635	6,550	10,000	
ECBM65	5	1.000	28.23	10	43%	1,692	2,714	4,216	5,851		
ECBL245	5	0.474	34.54	Direct drive	46%			2,211			
ECBH65	5	1.875	52.94	10	43%		1,447	2,249	3,121		
ECBM65	5	1.000	55.56	5	47%		1,362	2,196	3,103	4,807	6,511
ECBL125	5	0.474	69.08	Direct drive	52%			1,162	1,910	3,404	4,898
ECBM245	5	1.000	72.92	Direct drive	46%			1,048			
ECBH65	5	1.875	104.17	5	47%			1,171	1,655	2,564	3,473
ECBL65	5	0.474	138.16	Direct drive	55%					1,720	2,513
ECBM125	5	1.000	145.83	Direct drive	52%					1,612	2,320
ECBH125	5	1.875	273.44	Direct drive	52%						1,237
ECBM65	5	1.000	291.67	Direct drive	55%						1,191
ECBH65	5	1.875	546.88	Direct drive	55%						1,942
											1,036

5-Ton Electric Cylinders			
	Maximum Rise		Cylinder Tube Torque (in*lb) Per Pound Thrust
	Vertical Operation	Horizontal Operation	
ACME Screw			
ECAL	59"	44"	.131
ECAM	63"	47"	.151
ECAH	59"	44"	.171
Ball Screw			
ECBL	54"	40"	.084
ECBM	54"	40"	.178
ECBH	59"	44"	.332

Note: For proper model selection refer to Selection Guidelines on page 126.

ELECTRIC CYLINDERS QUICK REFERENCE

Use the following charts to select the electric cylinder that best fits your application. Refer to drawings on page 133. Contact Joyce/Dayton with questions regarding the proper selection of electric cylinders.

10-Ton Thrust Capacity Electric Cylinders													
Model	Max Static Capacity (tons)	Screw Lead (in)	Linear Speed (in/min)	External Gearbox Ratio	Estimated Efficiency	Max Dynamic Load at HP (lbs)							
						.33HP	.5HP	.75HP	1HP	1.5HP	2HP	3HP	5HP
ACME Screw													
ECAL2410	10	0.250	1.76	10	10%	5,417	9,111	14,543	19,976				
ECAL2410	10	0.250	1.71	10	10%							20,000	
ECAM2410	10	0.500	3.53	10	16%	4,468	7,515	11,996	16,872				
ECAM2410	10	0.500	3.42	10	17%							20,000	
ECAH2410	10	0.666	4.70	10	18%	3,811	6,409	10,231	14,390				
ECAH2410	10	0.666	4.55	10	19%							20,000	
ECAL810	10	0.250	5.29	10	12%	2,134	3,689	5,977	8,468				
ECAL810	10	0.250	5.13	10	13%							20,000	
ECAM2410	10	0.500	6.94	5	18%		3,554	6,112	8,896	14,126	19,355		
ECAM2410	10	0.500	7.29	5	19%							20,000	
ECAH2410	10	0.666	9.25	5	20%		3,031	5,213	7,587	12,047	16,508		
ECAH2410	10	0.666	9.71	5	21%							20,000	
ECAM810	10	0.500	10.59	10	20%		3,043	4,930	6,984				
ECAM810	10	0.500	10.25	10	21%							20,000	
ECAH810	10	0.666	14.10	10	23%		2,595	4,205	5,957				
ECAH810	10	0.666	14.10	10	24%							20,000	
ECAL2410	10	0.250	18.23	Direct drive	14%					2,440			
ECAM810	10	0.500	20.83	5	22%			2,367	3,503	5,637	7,771		
ECAM810	10	0.500	21.88	5	23%							11,611	19,837
ECAH810	10	0.666	27.75	5	25%			2,019	2,988	4,808	6,628		
ECAH810	10	0.666	29.14	5	26%							9,903	16,919
ECAM2410	10	0.500	36.46	Direct drive	23%					2,012			
ECAL810	10	0.250	54.69	Direct drive	16%							2,461	4,732
ECAM810	10	0.500	109.38	Direct drive	26%							2,030	3,903
ECAH810	10	0.666	145.69	Direct drive	29%								3,329
Ball Screw													
ECBL2410	10	0.474	3.34	10	34%	10,130	17,038	20,000					
ECBL2410	10	0.474	6.58	5	39%	4,113	8,057	13,858	20,000				
ECBM2410	10	1.000	7.06	10	34%	4,798	8,071	12,883	18,121				
ECBM2410	10	1.000	6.83	10	36%							20,000	
ECBL810	10	0.474	10.03	10	43%	3,990	6,899	11,178	15,834				
ECBL810	10	0.474	9.71	10	46%							20,000	
ECBH2410	10	1.875	13.24	10	34%	2,559	4,304	6,871	9,664				
ECBM2410	10	1.000	13.89	5	39%		3,817	6,565	9,554	15,171	20,000		
ECBL810	10	0.474	19.74	5	47%		2,999	5,366	7,942	12,781	17,619		
ECBL810	10	0.474	19.11	5	50%							20,000	
ECBM810	10	1.000	21.18	10	43%		3,268	5,295	7,501				
ECBM810	10	1.000	20.50	10	46%							20,000	
ECBH2410	10	1.875	26.04	5	39%		2,036	3,501	5,096	8,091	11,086		
ECBL2410	10	0.474	34.54	Direct drive	49%					4,562			
ECBH810	10	1.875	39.71	10	43%			2,824	4,000				
ECBM810	10	1.000	41.67	5	47%			2,542	3,762	6,054	8,346		
ECBM810	10	1.000	43.75	5	49%							12,470	20,000
ECBM2410	10	1.000	72.92	Direct drive	49%					2,161			
ECBH810	10	1.875	78.13	5	47%				2,006	3,229	4,451		
ECBH810	10	1.875	82.03	5	49%							6,651	11,363
ECBL810	10	0.474	103.62	Direct drive	56%						2,478	4,602	8,849
ECBM810	10	1.000	218.75	Direct drive	56%							2,180	4,192
ECBH810	10	1.875	410.16	Direct drive	56%								2,236

10-Ton Electric Cylinders			
	Maximum Rise		Cylinder Tube Torque (in*lb) Per Pound Thrust
	Vertical Operation	Horizontal Operation	
ACME Screw			
ECAL	84"	63"	.161
ECAM	60"	45"	.195
ECAH	76"	57"	.228
Ball Screw			
ECBL	38"	28"	.084
ECBM	38"	28"	.178
ECBH	41"	31"	.332

Note: For proper model selection refer to Selection Guidelines on page 129.

ELECTRIC CYLINDERS QUICK REFERENCE

Use the following charts to select the electric cylinder that best fits your application. Refer to drawings on page 134. Contact Joyce/Dayton with questions regarding the proper selection of electric cylinders.

20-Ton Thrust Capacity Electric Cylinders														
Model	Max Static Capacity (tons)	Screw Lead (in)	Linear Speed (in/min)	External Gearbox Ratio	Estimated Efficiency	Max Dynamic Load at HP (lbs)								
						.33HP	.5HP	.75HP	1HP	1.5HP	2HP	3HP	5HP	
ACME Screw														
ECAL2420	20	0.250	1.76	10	8%		6,459	10,813	15,552					
ECAL2420	20	0.250	1.71	10	8%								40,000	
ECAM2420	20	0.500	3.53	10	13%		5,484	9,181	13,205					
ECAM2420	20	0.500	3.42	10	14%								40,000	
ECAH2420	20	0.750	5.29	10	16%		4,560	7,634	10,979					
ECAH2420	20	0.750	5.13	10	17%								38,366	
ECAM2420	20	0.500	6.94	5	15%			4,305	6,621	10,972	15,324			
ECAM2420	20	0.500	7.29	5	15%								23,176	39,948
ECAM820	20	0.500	10.59	10	17%				5,276					
ECAM820	20	0.500	10.25	10	18%								19,447	
ECAH820	20	0.750	15.38	10	22%				4,387					
ECAH820	20	0.750	14.89	10	23%								16,170	
ECAL2420	20	0.250	18.23	Direct drive	11%								4,701	9,678
ECAM820	20	0.500	20.83	5	19%					4,127	5,935			
ECAM820	20	0.500	21.88	5	19%								9,218	16,187
ECAH820	20	0.750	31.25	5	23%						4,935			
ECAH820	20	0.750	32.81	5	24%								7,665	13,459
Ball Screw														
ECBL2420	20	0.500	3.53	10	33%	7,425	13,710	22,953	33,012					
ECBL2420	20	0.500	3.42	10	35%								40,000	
ECBL2420	20	0.500	6.94	5	37%		5,442	10,763	16,553	27,431	38,309			
ECBL2420	20	0.500	7.29	5	39%								40,000	
ECBL820	20	0.500	10.59	10	43%		4,876	8,857	13,189					
ECBL820	20	0.500	10.25	10	45%								40,000	
ECBL820	20	0.500	20.83	5	47%				5,797	10,317	14,837			
ECBL820	20	0.500	21.88	5	48%								23,046	40,000
ECBL2420	20	0.500	36.46	Direct drive	49%						4,697			
ECBL820	20	0.500	109.38	Direct drive	55%									6,665

20-Ton Electric Cylinders			
	Maximum Rise		Cylinder Tube Torque
	Vertical Operation	Horizontal Operation	(in*lb) Per Pound Thrust
ACME Screw			
ECAL	100"	75"	.178
ECAM	78"	58"	.210
ECAH	88"	66"	.244
Ball Screw			
ECBL	72"	54"	.089

Selection Guidelines:

- Select the model most closely matching your desired load and speed requirements. The charts are sorted by static capacity, then screw type (ACME or ball), then travel speed.
- To determine the maximum rise for the model selected, see maximum rise charts above and to the left.
- L, M, and H in the model numbers designate low, medium, or high screw leads.
- ECA models are not suitable for duty cycles greater than 25%.
- **All models with efficiencies >30% require a brake motor.**
- Models with efficiencies ≤30% are self-locking in the absence of vibration. A brake motor is required if vibration is present or faster stopping times are desired.
- Loads and speeds shown assume use of a 1750 rpm 3ph AC induction motor.
- Cylinder tube torque per pound thrust is the means to calculate how much torque must be resisted at the mounting locations of the cylinder. To calculate torque (in*lb), multiply the value in the chart times the load in pounds.
- When ordering cylinders with a ComDRIVE the reducer listed in the part number should specify the proper 4 letter ComDRIVE shaft code from page 121. Units with a "direct drive" listing should specify the proper 4 letter motor mount code listed on page 121.

ELECTRIC CYLINDERS

2 1/2 TON ELECTRIC CYLINDER

ECA (ACME SCREW)
ECB (BALL SCREW)

STANDARD

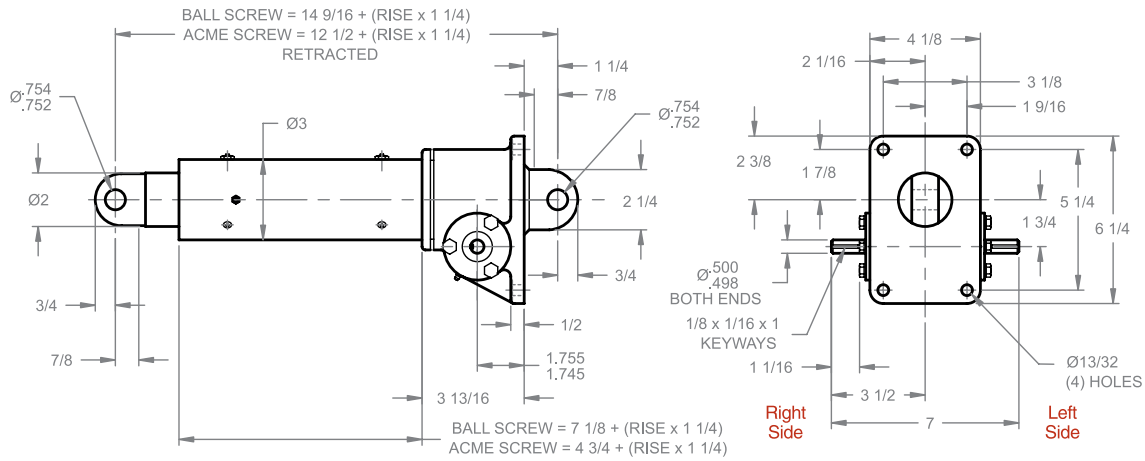

MOTOR MOUNT

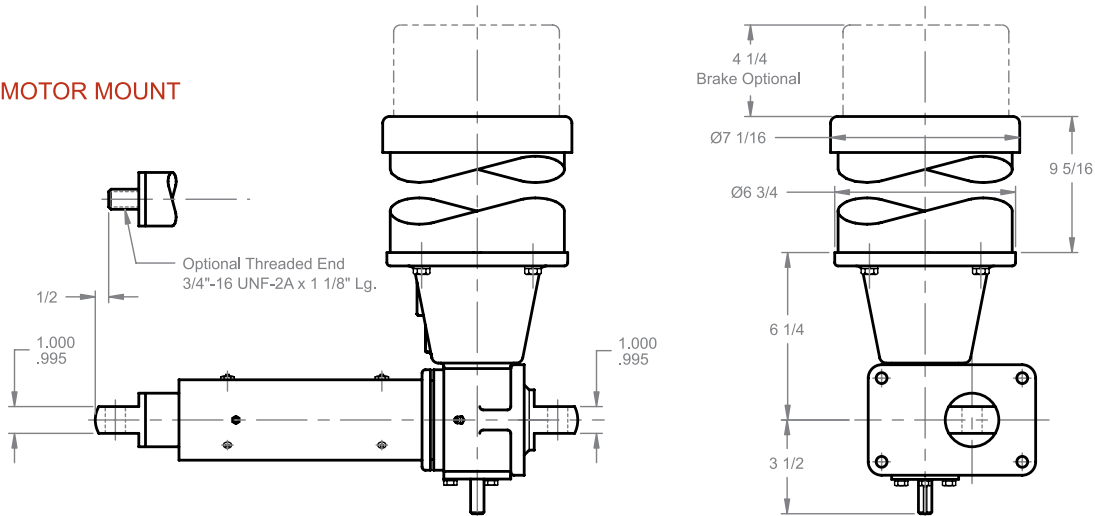

ComDRIVE®

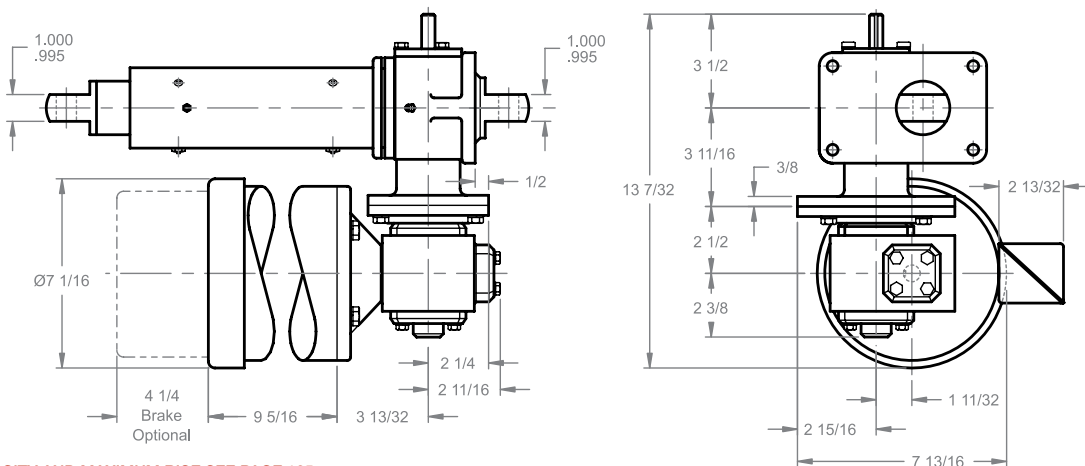

NOTE: FOR CAPACITY AND MAXIMUM RISE SEE PAGE 125.

Note: Drawings are artist's conception — not for certification; dimensions are subject to change without notice.

ELECTRIC CYLINDERS

3 TON ELECTRIC CYLINDER

ECA (ACME SCREW)
ECB (BALL SCREW)

STANDARD

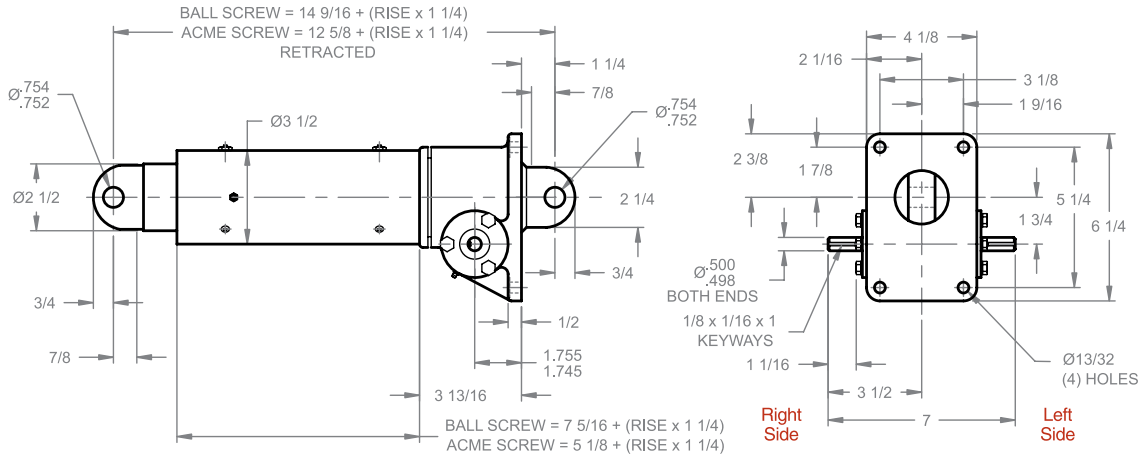

MOTOR MOUNT

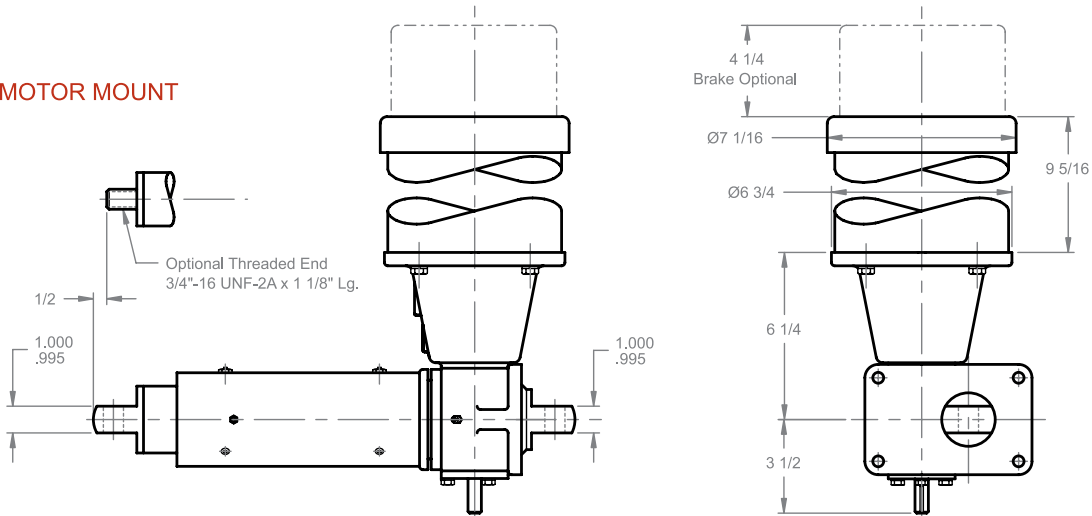

ComDRIVE®

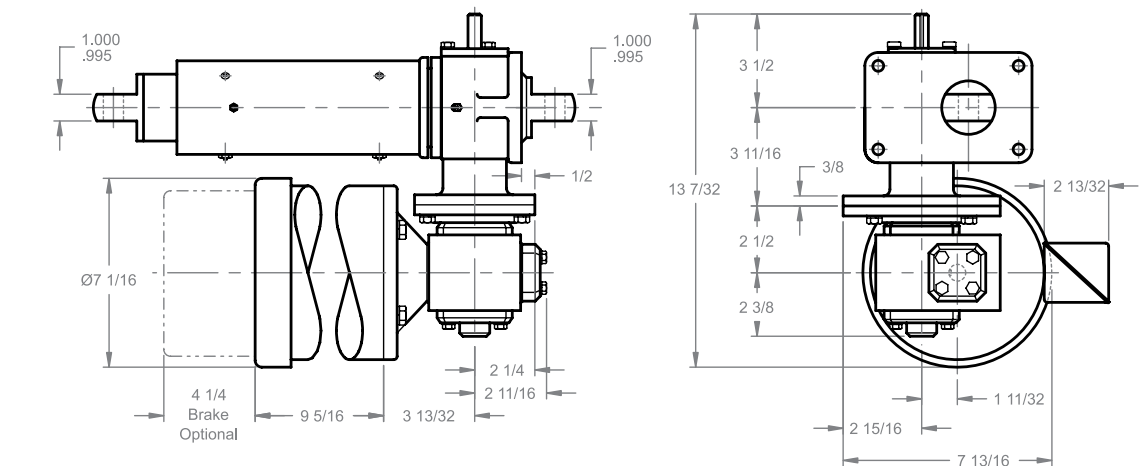

NOTE: FOR CAPACITY AND MAXIMUM RISE SEE PAGE 126.

Note: Drawings are artist's conception — not for certification; dimensions are subject to change without notice.

ELECTRIC CYLINDERS

5 TON ELECTRIC CYLINDER

ECA (ACME SCREW)
ECB (BALL SCREW)

STANDARD

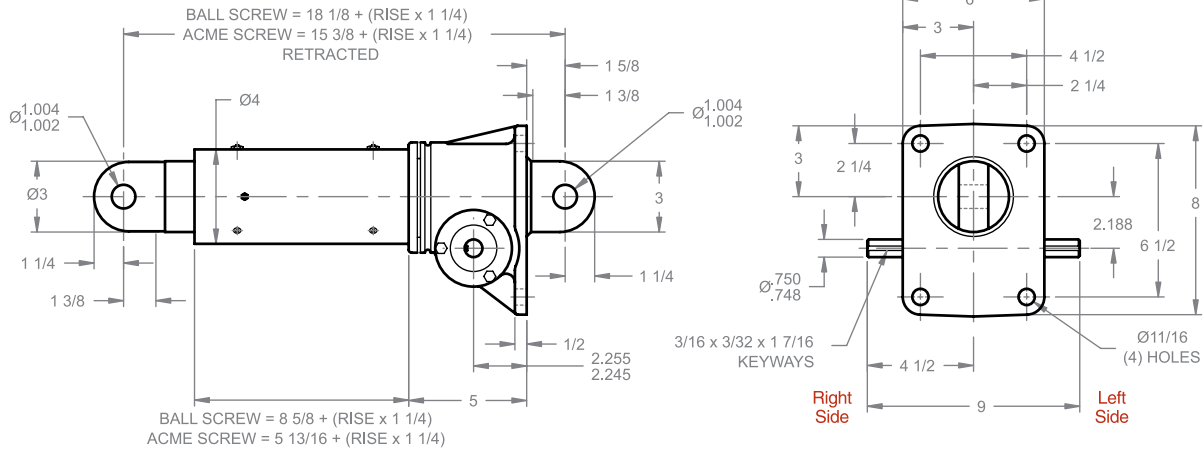

MOTOR MOUNT

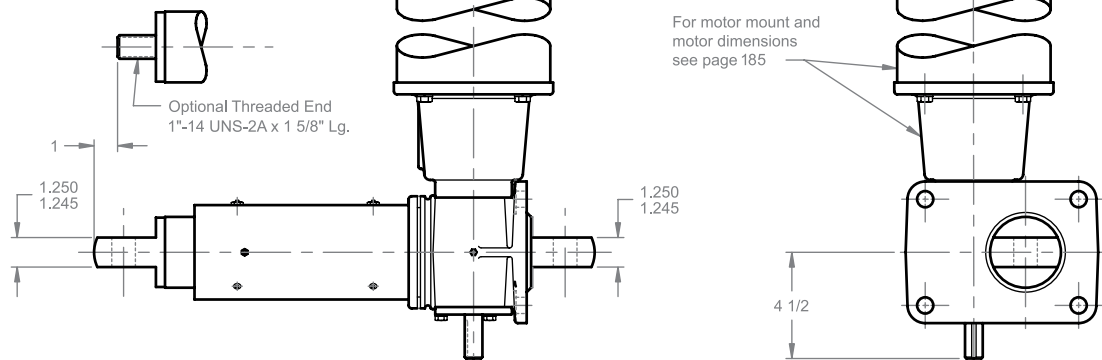

ComDRIVE®

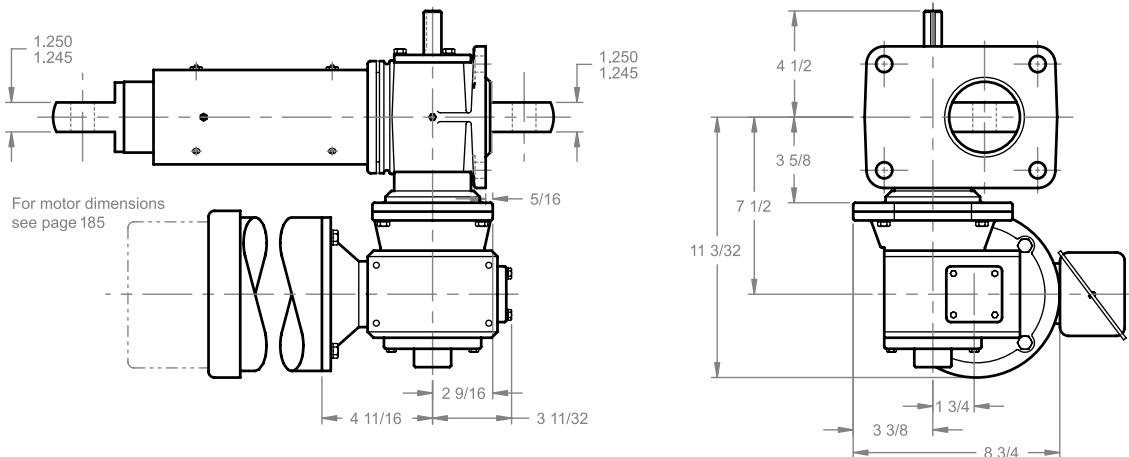

NOTE: FOR CAPACITY AND MAXIMUM RISE SEE PAGE 127.

Note: Drawings are artist's conception — not for certification; dimensions are subject to change without notice.

ELECTRIC CYLINDERS

10 TON ELECTRIC CYLINDER

ECA (ACME SCREW)
ECB (BALL SCREW)

STANDARD

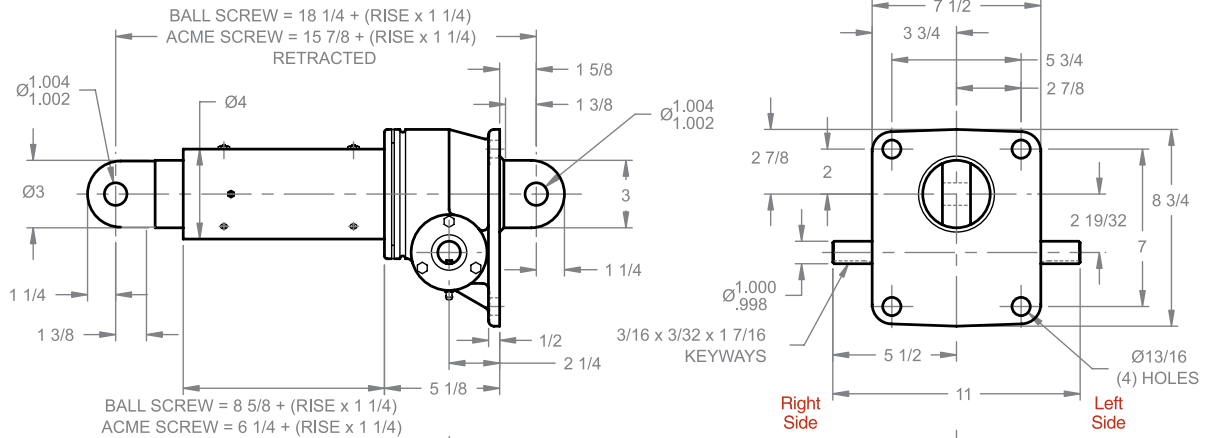

MOTOR MOUNT

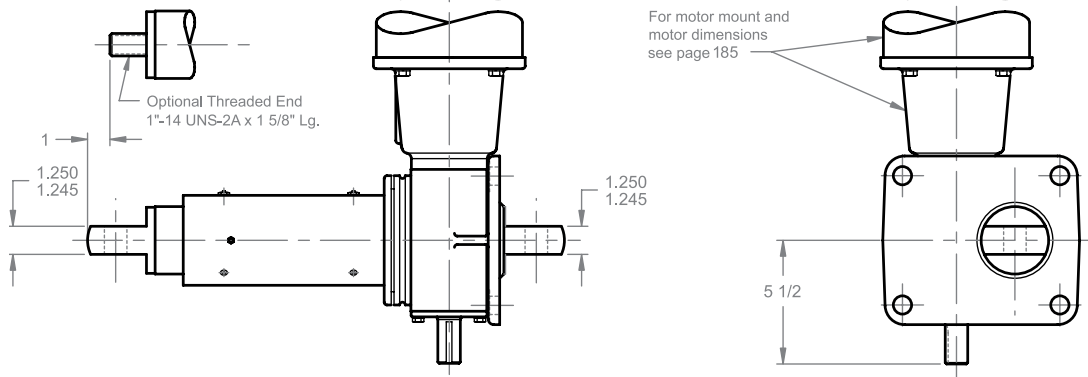

ComDRIVE®

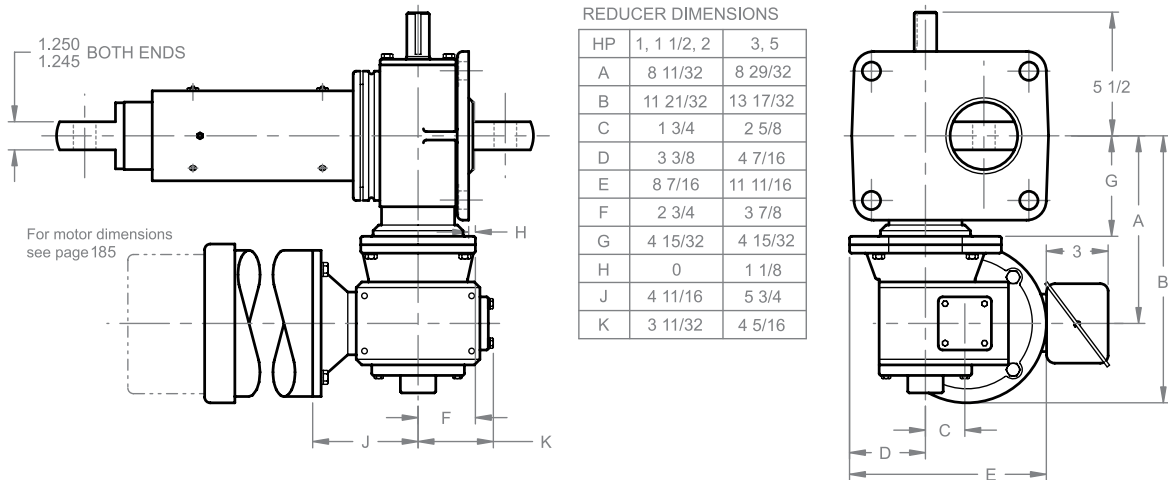

NOTE: FOR CAPACITY AND MAXIMUM RISE SEE PAGE 128.

Note: Drawings are artist's conception — not for certification; dimensions are subject to change without notice.

ELECTRIC CYLINDERS

20 TON ELECTRIC CYLINDER

ECA (ACME SCREW)
ECB (BALL SCREW)

STANDARD

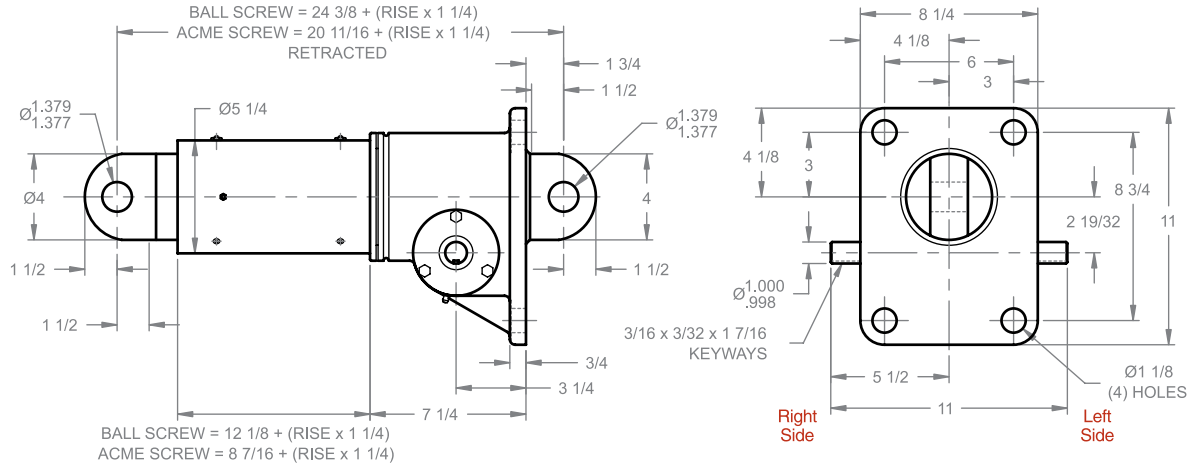

MOTOR MOUNT

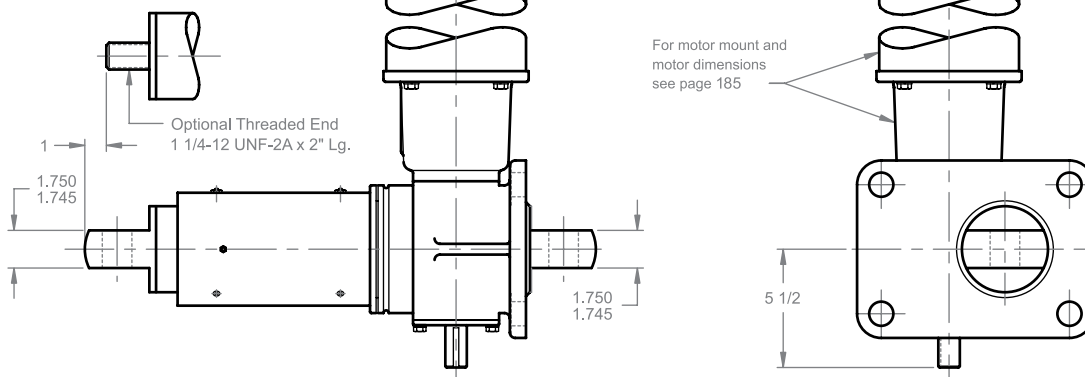

ComDRIVE®

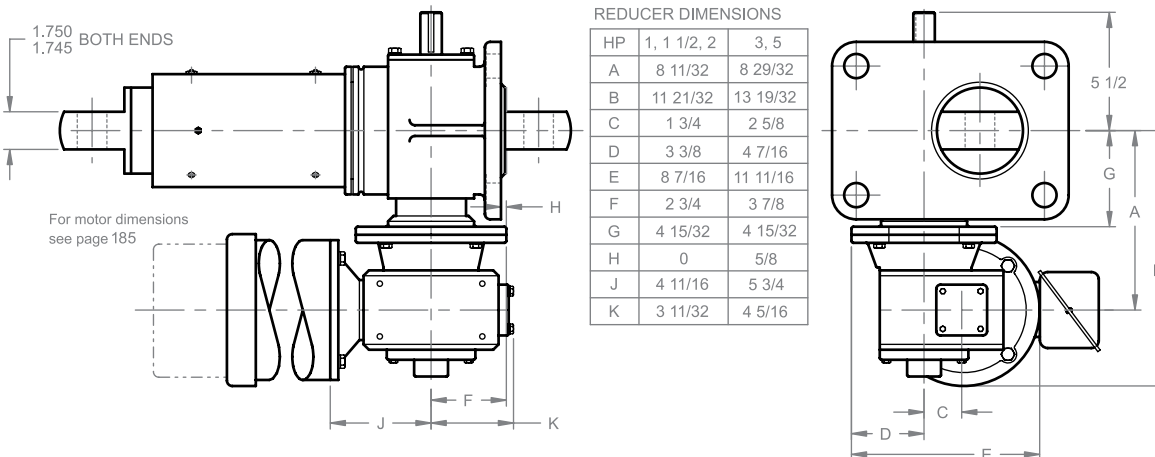

NOTE: FOR CAPACITY AND MAXIMUM RISE SEE PAGE 129.

Note: Drawings are artist's conception — not for certification; dimensions are subject to change without notice.