

Versatile Joyce machine screw jacks lift and precisely position all kinds of loads from 250 pounds to 250 tons.

Upright or inverted, these precision jacks operate at full capacity whether the load is in tension or compression. WJ and RWJ series single lead jacks are self-locking under full lifting capacity. DWJ and DRWJ double lead series jacks offer increased travel speed.

Alloy steel input shafts, aluminum bronze wormgears and tapered roller or ball thrust bearings provide rugged reliability.

Double input shafts are standard. Single input shafts are available with right or left hand extension or additional length. Jacks are available with one of four standard end conditions or special ends to meet your requirements. All jack designs can be fitted with protective boots.

An optional anti-backlash feature (pages 180 and 181) compensates for thread wear, assuring minimum play between lifting screw and wormgear for smooth, precise operation. Jacks equipped with the anti-backlash feature are rated at full capacity under static conditions. For anti-backlash jack capacity under dynamic conditions, please contact Joyce/Dayton.

Joyce/Dayton can customize machine screw jacks to meet your specifications.

MACHINE SCREW JACKS

Joyce/Dayton offers
Machine Screw Jacks
in several designs including:

- Translating
- Keyed for non-rotation
- Keyed for traveling nut (KFTN)
- Double clevis
- Trunnion

A guide for ordering
is on pages 20 and 21.



MACHINE SCREW JACKS ORDERING INFORMATION

Instructions: Select a model number from this chart.

Miniature	1-Ton	2-Ton	2-Ton Reverse Base	3-Ton	5-Ton	10-Ton	15-Ton	20-Ton
WJ250 WJ500* WJ1000	WJ51 WJ201	WJT62 WJT122 WJT242 WJT252	RWJT62 RWJT122 RWJT242 RWJT252	WJ63 WJ123 WJ243 WJ253	WJT65 WJT125 WJT245 WJT255	WJ810 WJ2410 WJ2510	WJ815 WJ2415 WJ2515	WJ820 WJ2420 WJ2520
		DWJ62* DWJ122* DWJ242*	DRWJ62* DRWJ122* DRWJ242*	DWJ63* DWJ123* DWJ243*	DWJ65* DWJ125* DWJ245*	DWJ810* DWJ2410*	DWJ815* DWJ2415*	DWJ820* DWJ2420*
25-Ton	30-Ton	35-Ton	50-Ton	50-Ton Reverse Base	75-Ton	100-Ton	150-Ton	250-Ton
WJ1125 WJ3225	WJ1130 WJ3230	WJ1135 WJ3235	WJT1150 WJT3250	RWJT1150 RWJT3250	WJ1175 WJ3275	WJ12100 WJ36100	WJ12150 WJ36150	WJ50250
DWJ1125* DWJ3225*	DWJ1130* DWJ3230*							

Important Note: *Not self-locking, may lower under load. Brake motors or external locking systems are recommended.

D: Double Lead Screw

R: Reverse Base Jack, (only available on 2-ton and 50-ton jacks).

Sample Part Number: **WJT65U1N-18.50-STDX-STDX-B**

Jack Configuration



U=Upright **I=Inverted**

End Conditions

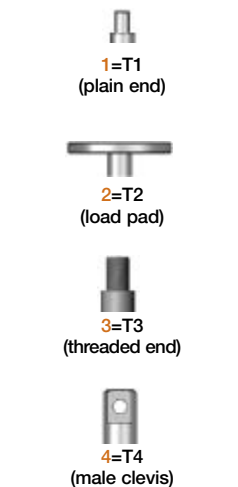

1=T1
(plain end)

2=T2
(load pad)

3=T3
(threaded end)

4=T4
(male clevis)

Left Side Shaft Code
(see below)



XXXX=Remove
STDX=Standard

For optional shaft codes, see page 21.

Right Side Shaft Code
(see below)

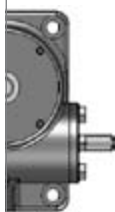

XXXX=Remove
STDX=Standard

For optional shaft codes, see page 21.

Additional Options

X=Standard Jack, no additional options

S=Additional Specification Required (comment as necessary)

Anti-Backlash p. 180

A=Split Nut
A90=A90 Design
A95=A95 Design

Protective Boots pp. 170-172
B=Protective Boot
D=Dual Protective Boot

Finishes p. 179
F1=Do Not Paint
F2=Epoxy Paint
F3=Outdoor Paint Process

Motor Options
M1=Less Motor
M2=Brake Motor
M3=Single Phase Motor (120VAC)
M4=50Hz Motor

Grease/Seals
H1=High Temperature Operation
H2=Food Grade

Screw Stops
ST0=Extending
ST1=Retracting
ST2=Both

• Specify as many options as needed

Machine Screw Jack Rise

Rise is travel expressed in inches and not the actual screw length.

Jack Designs



S=Translating **K=Keyed for Non Rotation** **N=Traveling Nut** **D=Double Clevis** **R=KFTN Trunnion***
T=Trunnion*

*Standard trunnion mounts available on 2-ton through 20-ton jacks. (See page 173)

MACHINE SCREW JACKS SHAFT CODES

Instructions: Select the appropriate shaft codes for both right and left hand shafts. One shaft code must be specified for each side of the jack.

Screw Stops (p. 10) and Boots (pp. 170-172)

Screw stops are optional on machine screw jacks. When specified, the closed height of the jack and/or the protection tube length may be increased.

When boots are added to machine screw jacks, the closed height of the jack may be increased.

Mechanical Counters (p. 177)

CNT0=0.001" Increments

Note: Contact Joyce/Dayton for availability and options.



Hand Wheels (p. 177)

HW04=4" dia

HW06=6" dia

HW08=8" dia

HW10=10" dia
HW12=12" dia



Recommended for self-locking jacks only.

Geared Potentiometers (p. 176)

POTA=0-10V (IP65)

POTB=4-20mA (IP65)

POTC=0-10V w/2 switches*

POTD=4-20mA w/2 switches*

*Optional IP65 rating available



Encoders and Electronic Limit Switches

ENCX=Encoder (p. 178)

ELS2=2 Position Electronic Switch (p. 174)

ELS4=4 Position Electronic Switch (p. 174)

ELS6=6 Position Electronic Switch (p. 174)



Motors for Systems and Direct Drives (p. 185)

- All standard motors are 3-phase, 208-230/460 VAC or 230/460 VAC. Other motor options are available. Specify the appropriate motor size from the chart on the right.
- Refer to the "Additional Options" chart on the preceding page as needed.
- Brake motors (M2) are recommended for jacks that are not self-locking, and jacks with double lead screws.
- If the motor frequency will be varied to provide a "soft" start an inverter duty motor may be required.

Motors

Size	Code
1/4 HP	K
1/3 HP	A
1/2 HP	B
3/4 HP	C
1 HP	D
1-1/2 HP	E
2 HP	F
3 HP	L
5 HP	G
7-1/2 HP	H
10 HP	I
15 HP	J

Motor Mounts (p. 185)

Ordering Example:

MMA A

MMA=56C

MMB=140TC

MMC=180TC

MMD=210TC

Motor code from chart at left



Standard motor adapters are aluminum.

Mechanical Limit Switches (pp. 174-175)

Ordering Example: **LA13**

Models		Number of DPDT Switches (see p. 175)	Available Positions									
Model	Code		1	2*	3	4	5	6*	7	8		
LS7-402	LI	NOTE: Will always be 0 for LS7 models	Left Side Shaft Options									
LS8-402	LA		Right Side Shaft Options									
LS8-404	LB											
LS9-502	LC											
LS9-503	LD											
LS9-504	LE											
LS9-505	LF											
LS9-506	LG											
LS9-507	LH											

- 2, 3, 5, 10, 15, and 20 ton jacks are available with positions #1, #3, and #5
- 25, 30, 35, 50, 75, 100, and 150 ton jacks are available with positions #1, #4, #7, and #8
- *These positions are not standard. Contact Joyce/Dayton with your requirements.

MACHINE SCREW JACKS SPECIFICATIONS

Model	Capacity	Screw Diameter (Inches)	Thread Pitch/Lead	Worm Gear Ratio	Worm Shaft Turns for 1" Travel	Tare Torque (Inch Lbs.)	Starting Torque (Inch Lbs.)	Operating Torque (Inch Lbs.)	Efficiency Rating % Approx.	Screw Torque (Inch Lbs.)	Basic Jack Weight (Lbs.)	Jack Weight per Inch Travel (Lbs.)
WJ250	250 lbs.	1/2	.125 pitch STUB ACME	5:1	40	1	.025W*	.018W* @ 500 RPM	23.0	.050W*	1.2	0.1
WJ500	500 lbs.	5/8	.125 pitch .250 lead STUB ACME	5:1	20	1	.041W*	.030W* @ 500 RPM	27.2	.079W*	1.3	0.1
WJ1000	1,000 lbs.	5/8	.125 pitch STUB ACME	5:1	40	1	.030W*	.021W* @ 500 RPM	19.9	.059W*	1.3	0.1
WJ51	1 ton	3/4	.200 pitch ACME 2C	5:1	25	3	.038W*	.026W* @ 500 RPM	25.0	.075W*	6	0.3
WJ201				20:1	100		.017W*	.009W* @ 500 RPM	15.9			
(R)WJT62	2 ton	1	.250 pitch ACME 2C	6:1	24	4	.041W*	.028W* @ 500 RPM	24.2	.098W*	15	0.3
(R)WJT122				12:1	48		.025W*	.015W* @ 500 RPM	22.0			
(R)WJT242				24:1	96		.018W*	.009W* @ 500 RPM	18.3			
(R)WJT252				25:1	100		.015W*	.0085W* @ 500 RPM	17.0			
D(R)WJ62			.250 pitch .500 lead ACME 2C	6:1	12		.057W*	.039W* @ 500 RPM	33.7	.139W*		
D(R)WJ122				12:1	24		.035W*	.022W* @ 500 RPM	30.5			
D(R)WJ242				24:1	48		.025W*	.013W* @ 500 RPM	25.4			

Important Note: Series DWJ double lead screw jacks and WJ500 screw jacks are not self-locking. Brake motors or external locking systems are recommended.

(R): Reverse Base Jack.

***W:** Load in pounds.

Tare Torque: Initial torque to overcome seal and normal assembly drag. This value must be added to starting torque or operating torque values.

Starting Torque: Torque value required to start moving a given load (dissipates to operating torque values once the load begins moving).

Operating Torque: Torque required to continuously raise a given load at the input RPM listed.

Note: If your actual input RPM is 20% higher or lower than the listed RPM, please refer to our JAX® program to determine actual torque values at your RPM.

Screw Torque: Torque required to resist screw rotation (Translating Design Jacks) and traveling nut rotation (Keyed for Traveling Nut Design Jacks).

Lead: The distance traveled axially in one rotation of the lifting screw.

Pitch: The distance from a point on a screw thread to a corresponding point on the next thread, measured axially.

MACHINE SCREW JACKS SPECIFICATIONS

Model	Capacity	Screw Diameter (Inches)	Thread Pitch/Lead	Worm Gear Ratio	Worm Shaft Turns for 1" Travel	Tare Torque (Inch Lbs.)	Starting Torque (Inch Lbs.)	Operating Torque (Inch Lbs.)	Efficiency Rating % Approx	Screw Torque (Inch Lbs.)	Basic Jack Weight (Lbs.)	Jack Weight per Inch Travel (Lbs.)
WJ815	15 ton	2 1/4	.500 pitch ACME 2C	8:1	16	30	.069W*	.047W* @ 200 RPM	21.1	.210W*	59	1.4
WJ2415				24:1	48		.036W*	.020W* @ 200 RPM	16.6			
WJ2515				25:1	100		.026W*	.015W* @ 200 RPM	10.2			
DWJ815		2 1/4	.333 pitch .666 lead ACME 2C	8:1	12		.079W*	.058W* @ 200 RPM	34.4			
DWJ2415				24:1	36		.041W*	.025W* @ 200 RPM	27.0			
WJ820	20 ton	2 1/2	.500 pitch ACME 2C	8:1	16	40	.075W*	.051W* @ 200 RPM	19.6	.227W*	77	1.9
WJ2420				24:1	48		.039W*	.022W* @ 200 RPM	15.4			
WJ2520				25:1	100		.029W*	.016W* @ 200 RPM	9.4			
DWJ820		2 1/2	.375 pitch .750 lead ACME 2C	8:1	10.67		.088W*	.061W* @ 200 RPM	24.5			
DWJ2420				24:1	32		.046W*	.026W* @ 200 RPM	19.3			
WJ1125	25 ton	3 3/8	.666 pitch Stub ACME	11:1	16	50	.088W*	.055W* @ 200 RPM	18.3	.313W*	164	3.1
WJ3225				32:1	48		.053W*	.025W* @ 200 RPM	13.5			
DWJ1125		3 3/8	.562 pitch 1.125 lead ACME 2C	11:1	9.5		.106W*	.067W* @ 200 RPM	25.1			
DWJ3225				32:1	28.5		.063W*	.030W* @ 200 RPM	18.6			
WJ1130	30 ton	3 1/2	.666 pitch ACME 2C	11:1	16	60	.088W*	.055W* @ 200 RPM	18.3	.313W*	164	3.0
WJ3230				32:1	48		.052W*	.025W* @ 200 RPM	13.5			
DWJ1130		3 1/2	.5625 pitch 1.125 lead ACME 2C	11:1	9.5		.107W*	.067W* @ 200 RPM	25.1			
DWJ3230				32:1	28.5		.064W*	.030W* @ 200 RPM	18.6			
WJ1135	35 ton	3 3/4	.666 pitch ACME 2C	11:1	16	70	.093W*	.057W* @ 200 RPM	17.4	.328W*	240	3.4
WJ3235				32:1	48		.055W*	.026W* @ 200 RPM	12.9			
(R)WJT1150	50 ton	4 1/2	.666 pitch ACME 2C	11:1	16	100	.095W*	.063W* @ 150 RPM	15.8	.378W*	387	6.1
(R)WJT3250				32:1	48		.050W*	.027W* @ 150 RPM	12.4			
WJ1175	75 ton	5	.666 pitch ACME 2C	11:1	16	155	.107W*	.067W* @ 150 RPM	14.8	.418W*	610	6.5
WJ3275				32:1	48		.056W*	.028W* @ 150 RPM	11.7			
WJ12100	100 ton	6	.750 pitch ACME 2C	12:1	16	205	.112W*	.072W* @ 90 RPM	13.9	.495W*	1010	10.0
WJ36100				36:1	48		.059W*	.031W* @ 90 RPM	10.8			
WJ12150	150 ton	7	1.00 pitch ACME 2C	12:1	12	300	.134W*	.084W* @ 90 RPM	15.7	.595W*	1350	12.2
WJ36150				36:1	36		.070W*	.037W* @ 90 RPM	12.1			
WJ50250	250 ton	9	1.00 pitch ACME 2C	50:1	50	500		.036W* @ 60 RPM	8.8	.711W*	3415	21.0

Important Note: Series DWJ double lead screw jacks and WJ500 screw jacks are not self-locking. Brake motors or external locking systems are recommended.

(R): Reverse Base Jack.

*W: Load in pounds.

Tare Torque: Initial torque to overcome seal and normal assembly drag. This value must be added to starting torque or operating torque values.

Starting Torque: Torque value required to start moving a given load (dissipates to operating torque values once the load begins moving).

Operating Torque: Torque required to continuously raise a given load at the input RPM listed.

Note: If your actual input RPM is 20% higher or lower than the listed RPM, please refer to our JAX® program to determine actual torque values at your RPM.

Screw Torque: Torque required to resist screw rotation (Translating Design Jacks) and traveling nut rotation (Keyed for Traveling Nut Design Jacks).

Lead: The distance traveled axially in one rotation of the lifting screw.

Pitch: The distance from a point on a screw thread to a corresponding point on the next thread, measured axially.

MACHINE SCREW JACKS COLUMN LOADING

Machine Screw Jack Column Loading Chart

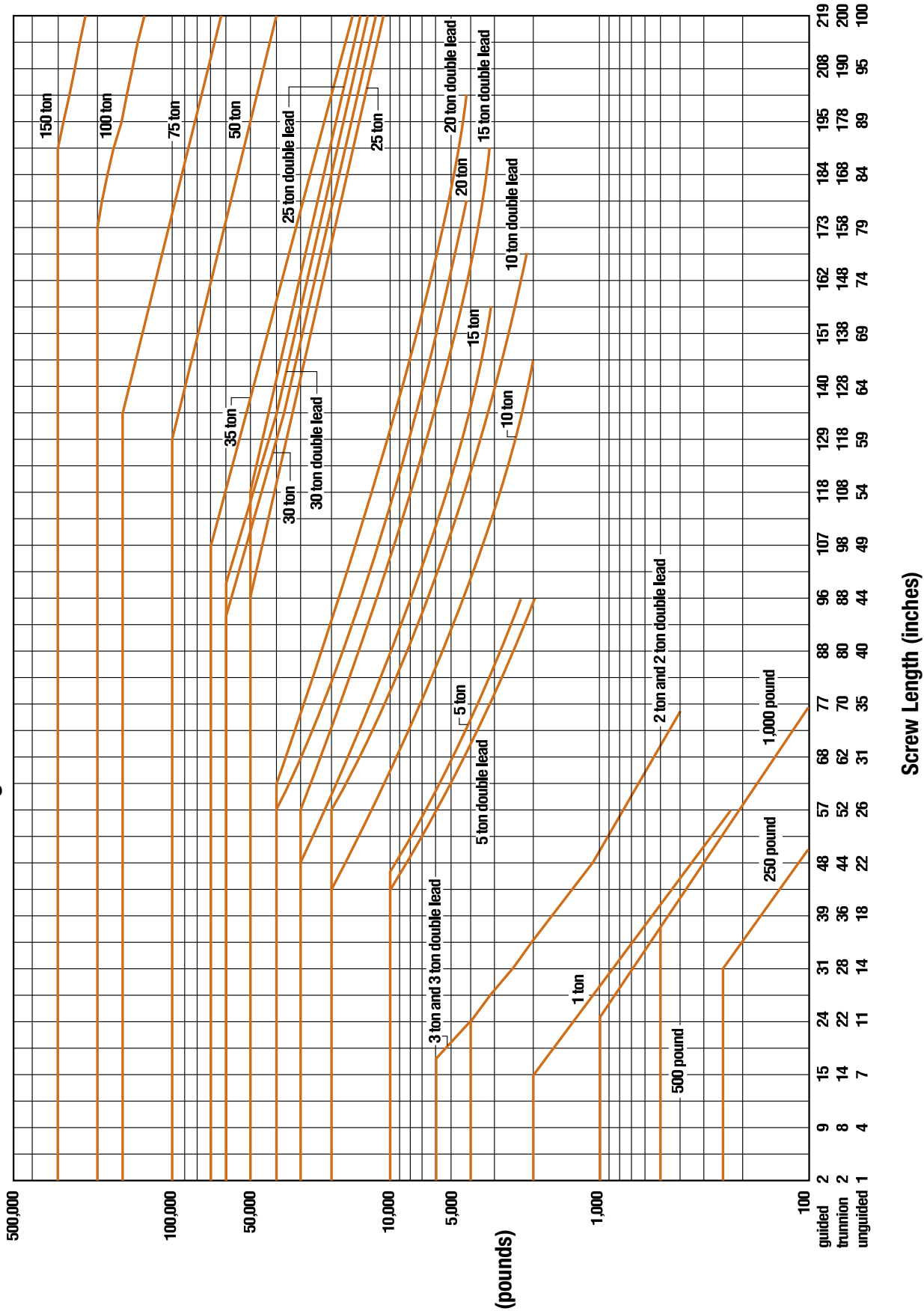

This chart includes a 2:1 Factor-of-Safety based on the Euler-Johnson equation for column loading (Oberg, Erik et al: Machinery's Handbook, 24th Edition, c. 1992 Industrial Press Inc.) The horizontal portion of each line represents the jack's maximum dynamic capacity. Under static conditions, these lines can be exceeded. Please contact factory for assistance.

MACHINE SCREW JACKS

250 POUND - 1/2" SCREW

WJ 250

Upright

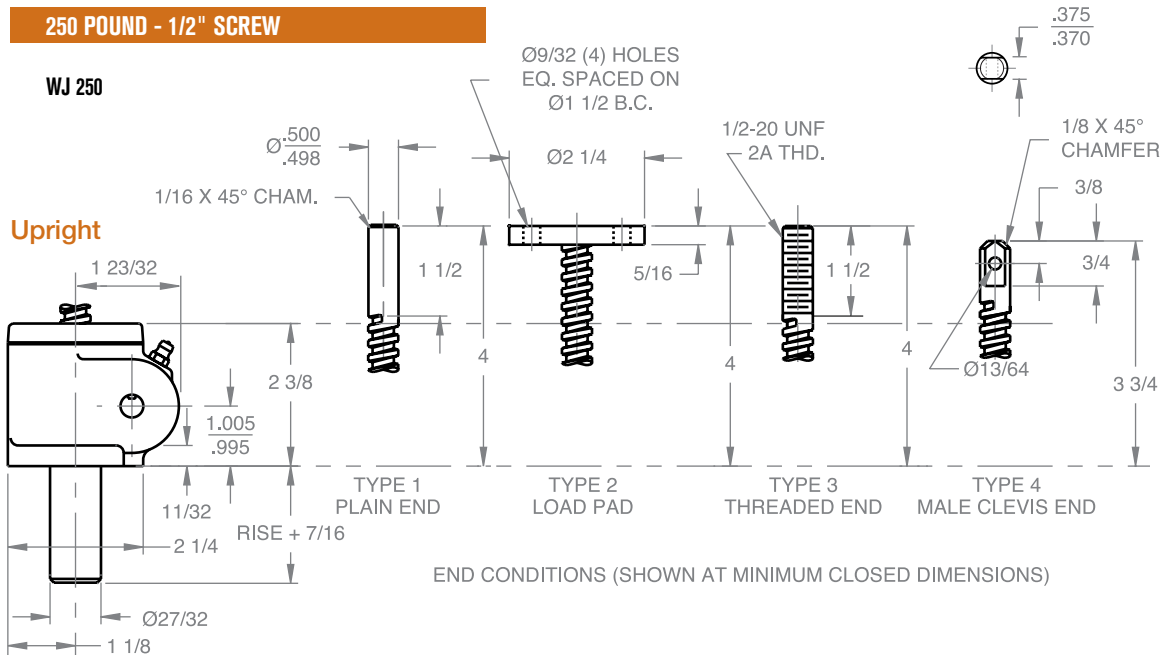

Upright
traveling nut

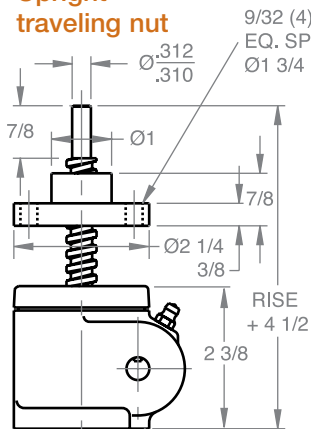

Typical Plan View

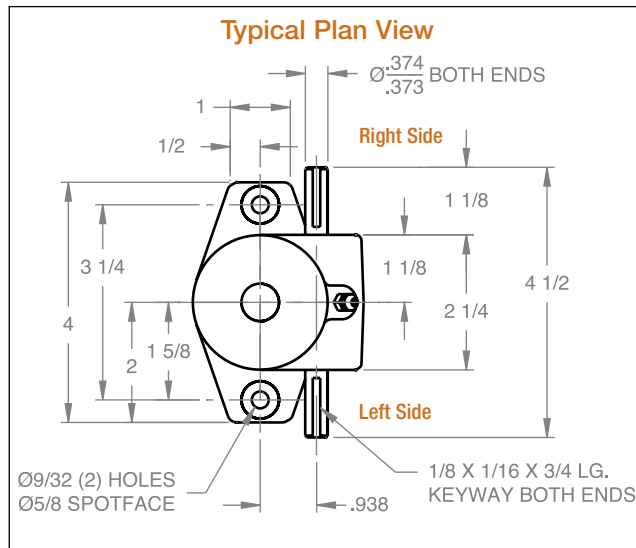

Inverted
traveling nut

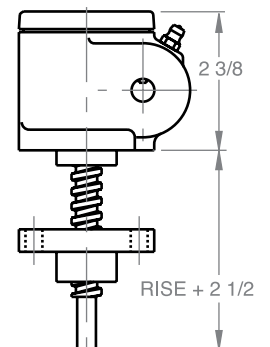

Inverted

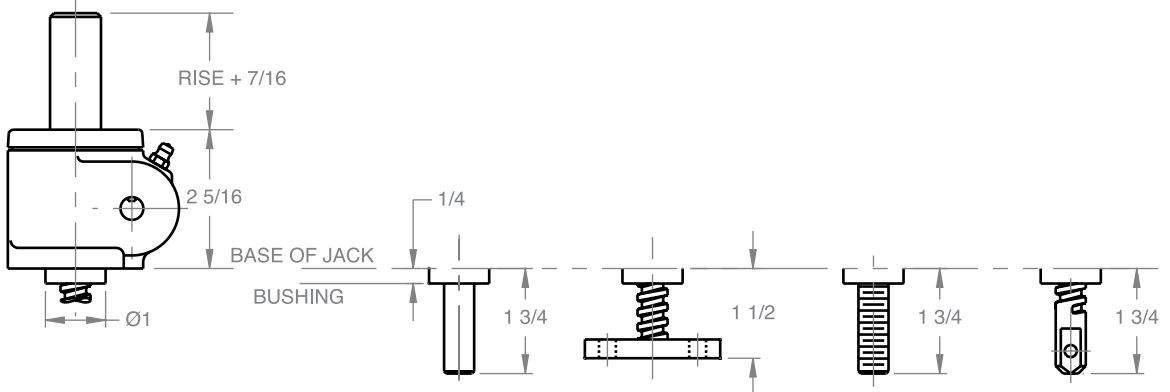

Material Notes: Housing and protection tube are aluminum. Lifting screw is cold drawn steel (CDS), Input shaft (worm) is 416 S.S.

Note: Drawings are artist's conception — not for certification; dimensions are subject to change without notice.

MACHINE SCREW JACKS

500 POUND - 5/8" SCREW

WJ 500

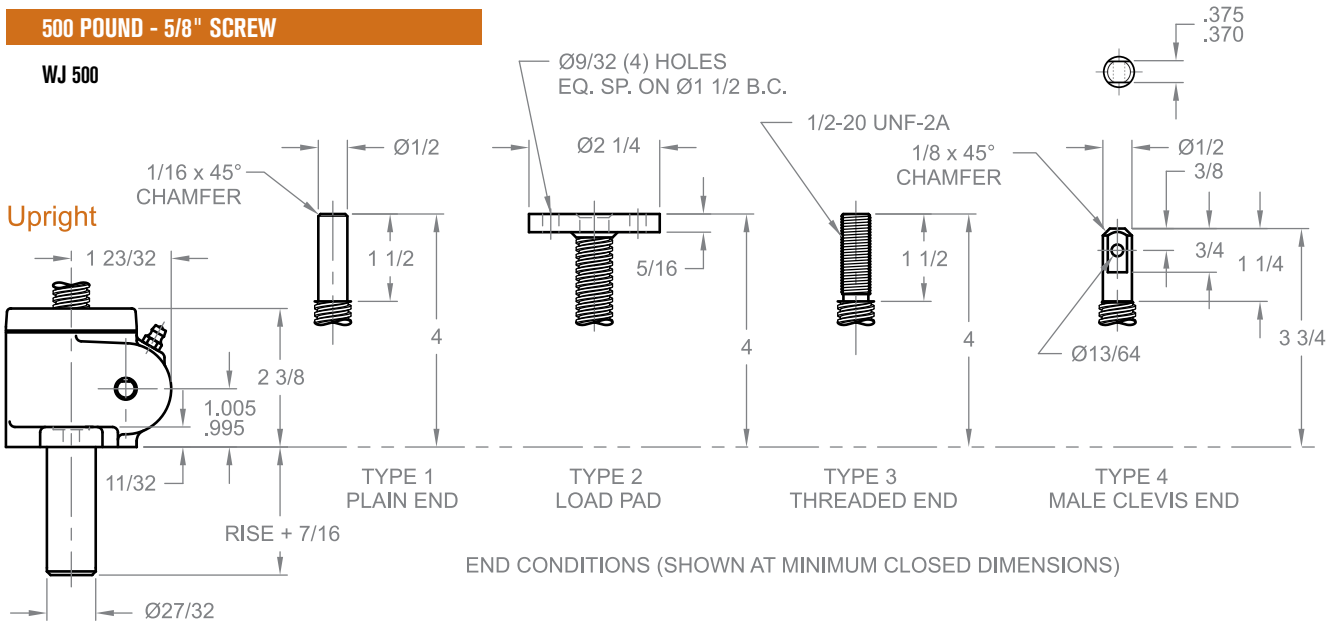

**Upright
traveling nut**

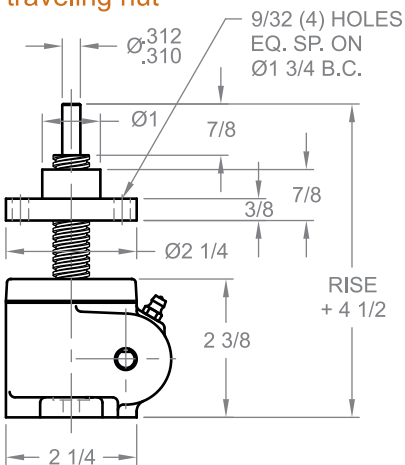

Typical Plan View

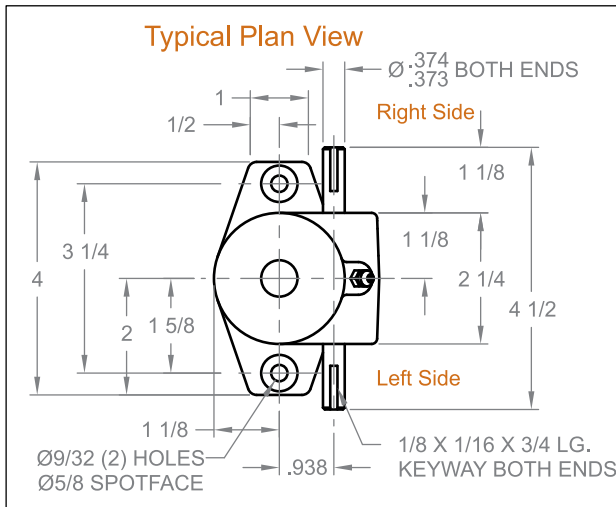

**Inverted
traveling nut**

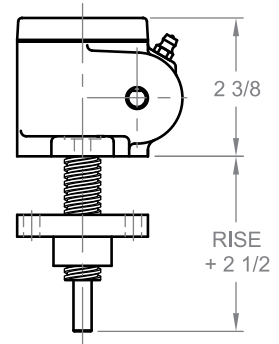

Inverted

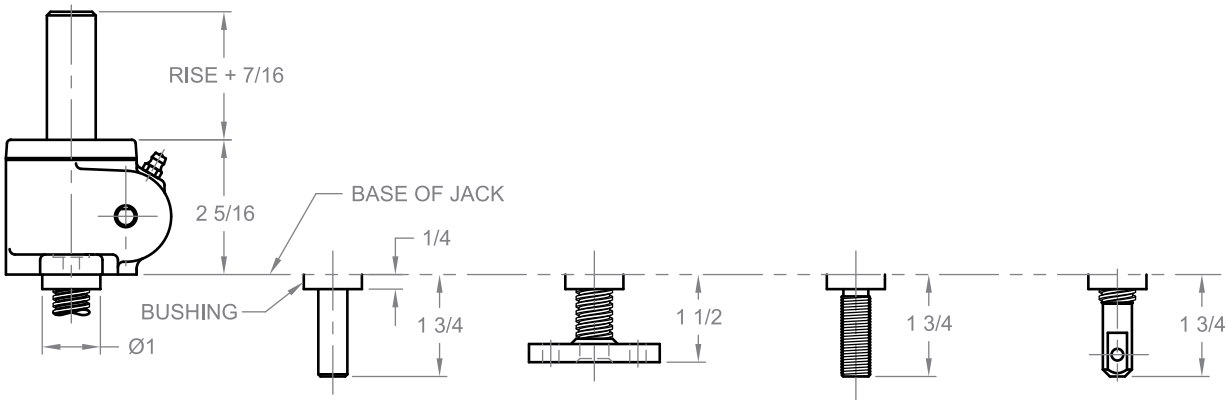

Material Notes: Housing and protection tube are aluminum. lifting screw is 304 S.S. Input shaft (worm) is 416 S.S.

Note: Drawings are artist's conception - not for certification; dimensions are subject to change without notice.

MACHINE SCREW JACKS

1000 POUND - 5/8" SCREW

WJ 1000

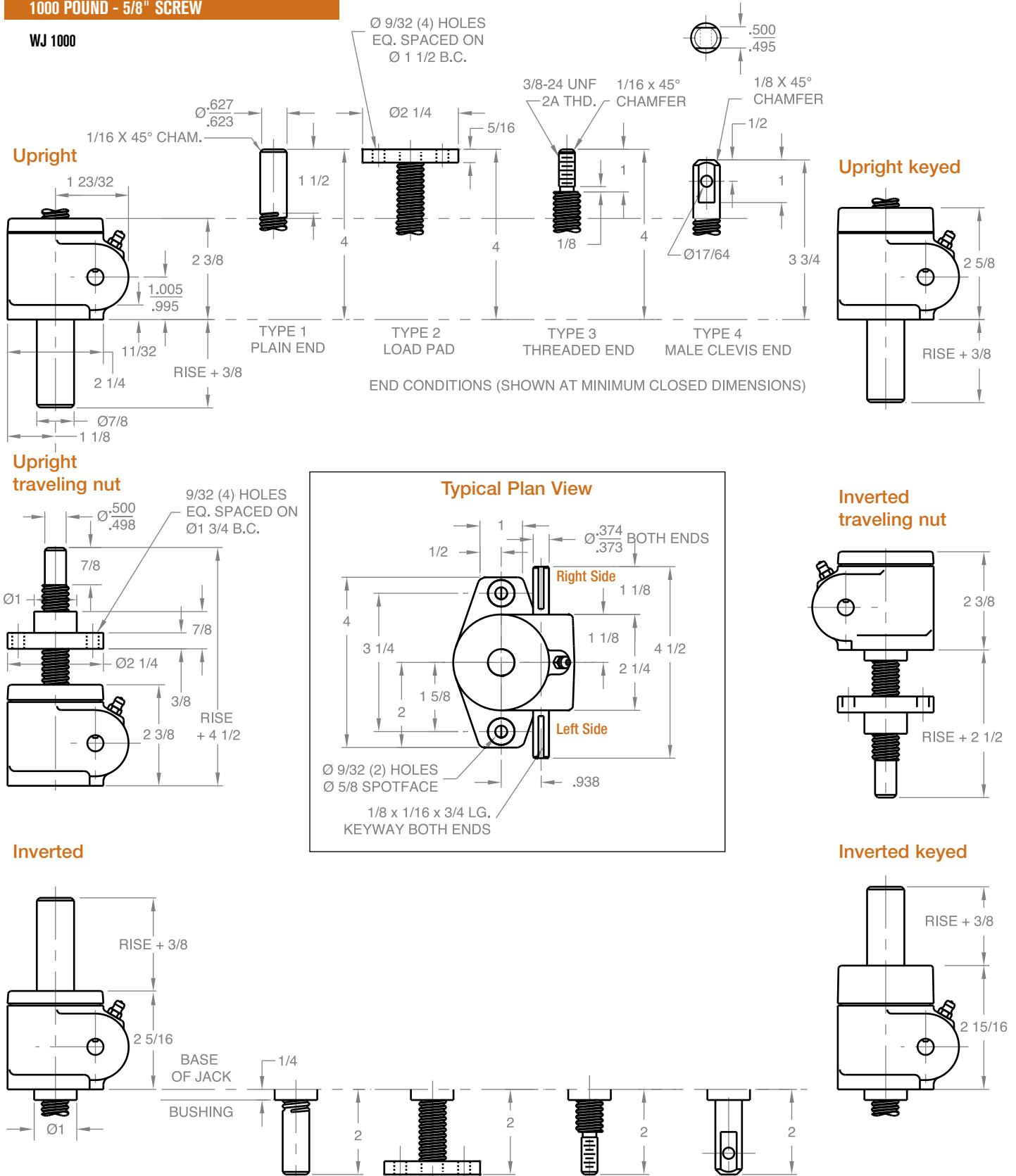

Material Notes: Housing and protection tube are aluminum. Lifting screw is 304 S.S. Input shaft (worm) is 416 S.S.

Note: Drawings are artist's conception — not for certification; dimensions are subject to change without notice.

MACHINE SCREW JACKS

1 TON - 3/4" SCREW

WJ 51 / WJ 201

Upright

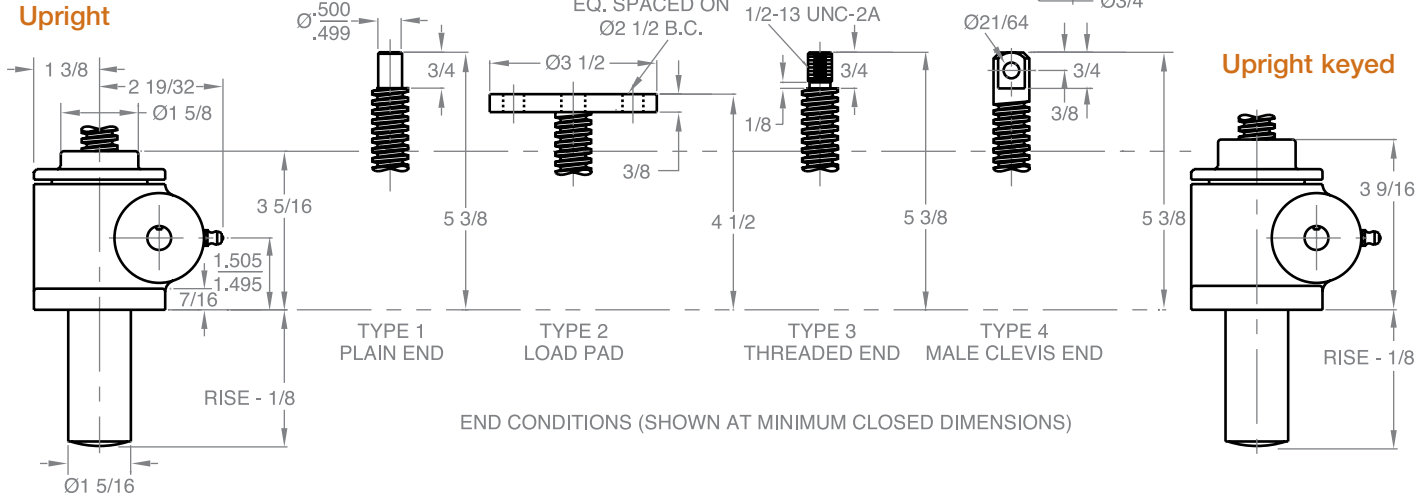

Upright traveling nut

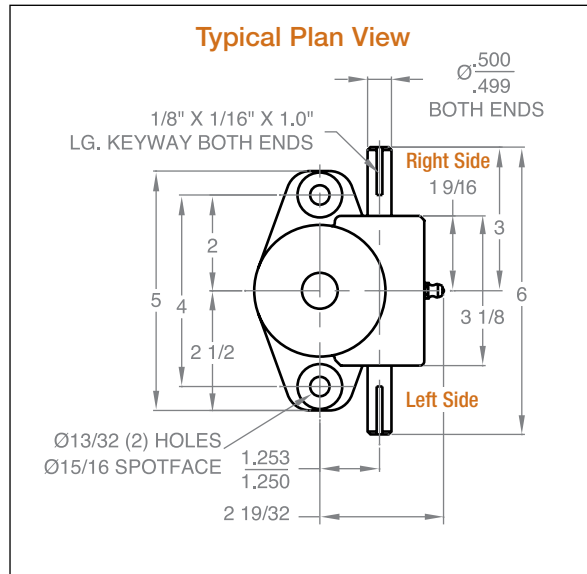
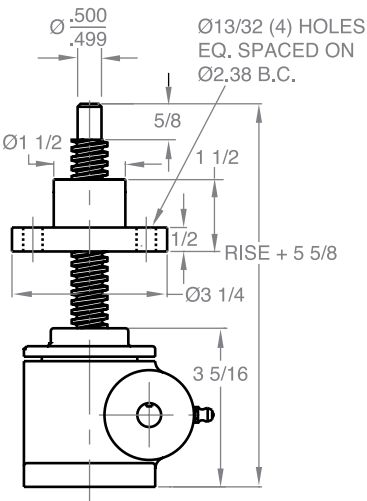

Inverted traveling nut

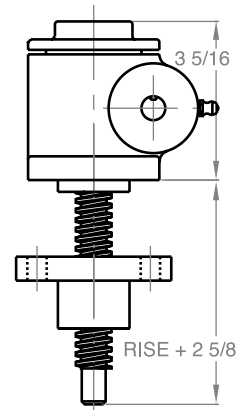

Inverted

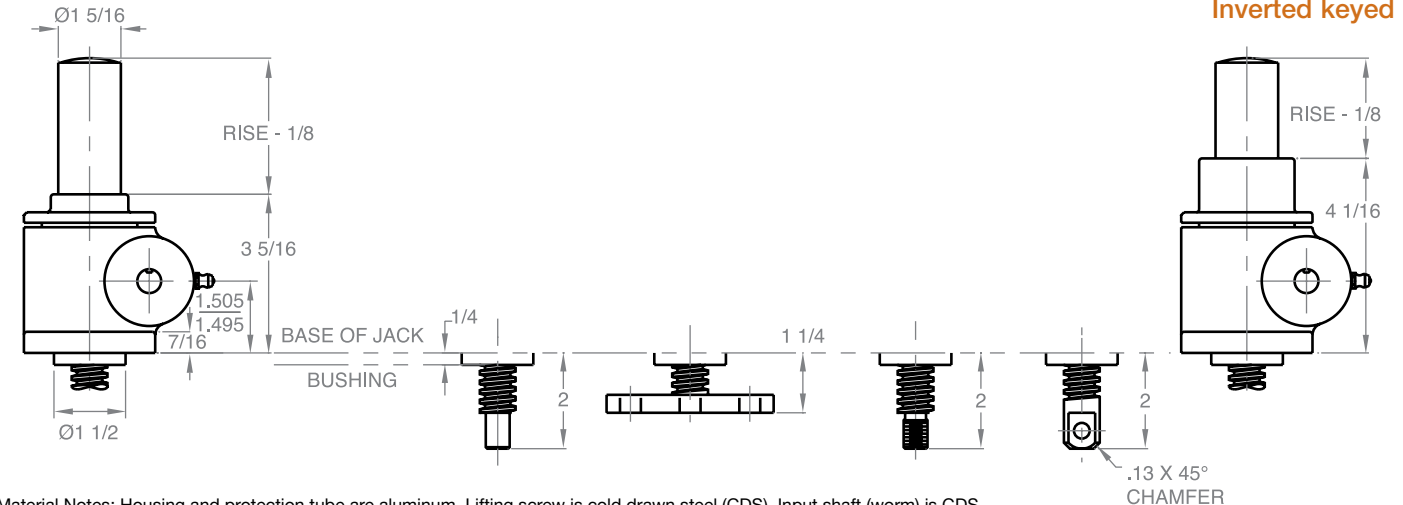

Material Notes: Housing and protection tube are aluminum. Lifting screw is cold drawn steel (CDS). Input shaft (worm) is CDS.

Note: Drawings are artist's conception — not for certification; dimensions are subject to change without notice.

MACHINE SCREW JACKS

2 TON - 1" SCREW

WJT 62 / DWJ 62
 WJT 122 / DWJ 122
 WJT 242 / DWJ 242
 WJT 252

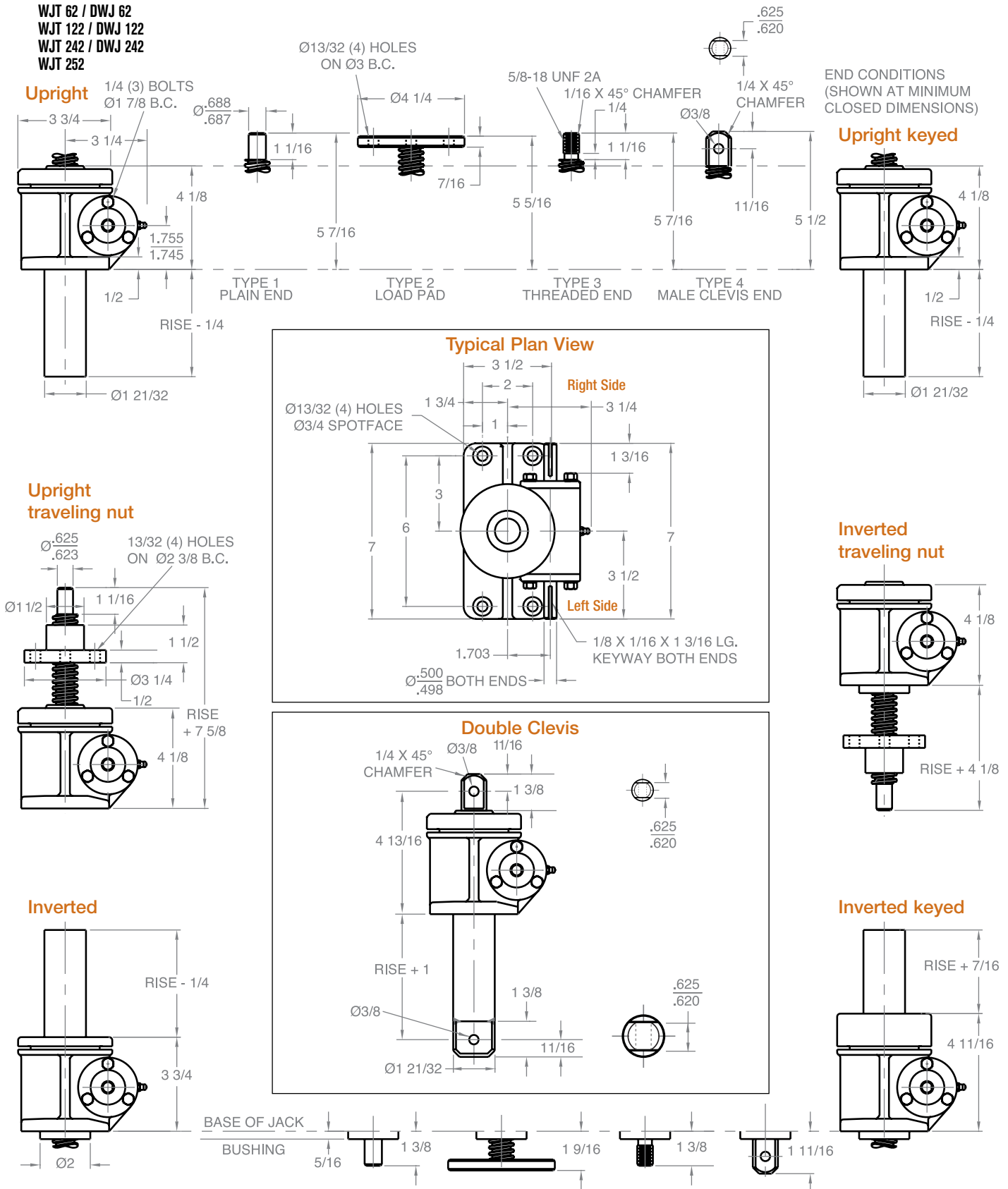

Note: Drawings are artist's conception — not for certification; dimensions are subject to change without notice.

MACHINE SCREW JACKS

3 TON - 1" SCREW

WJ 63 / WJ 123 / WJ 243 / WJ 253
 DWJ 63 / DWJ 123 / DWJ 243

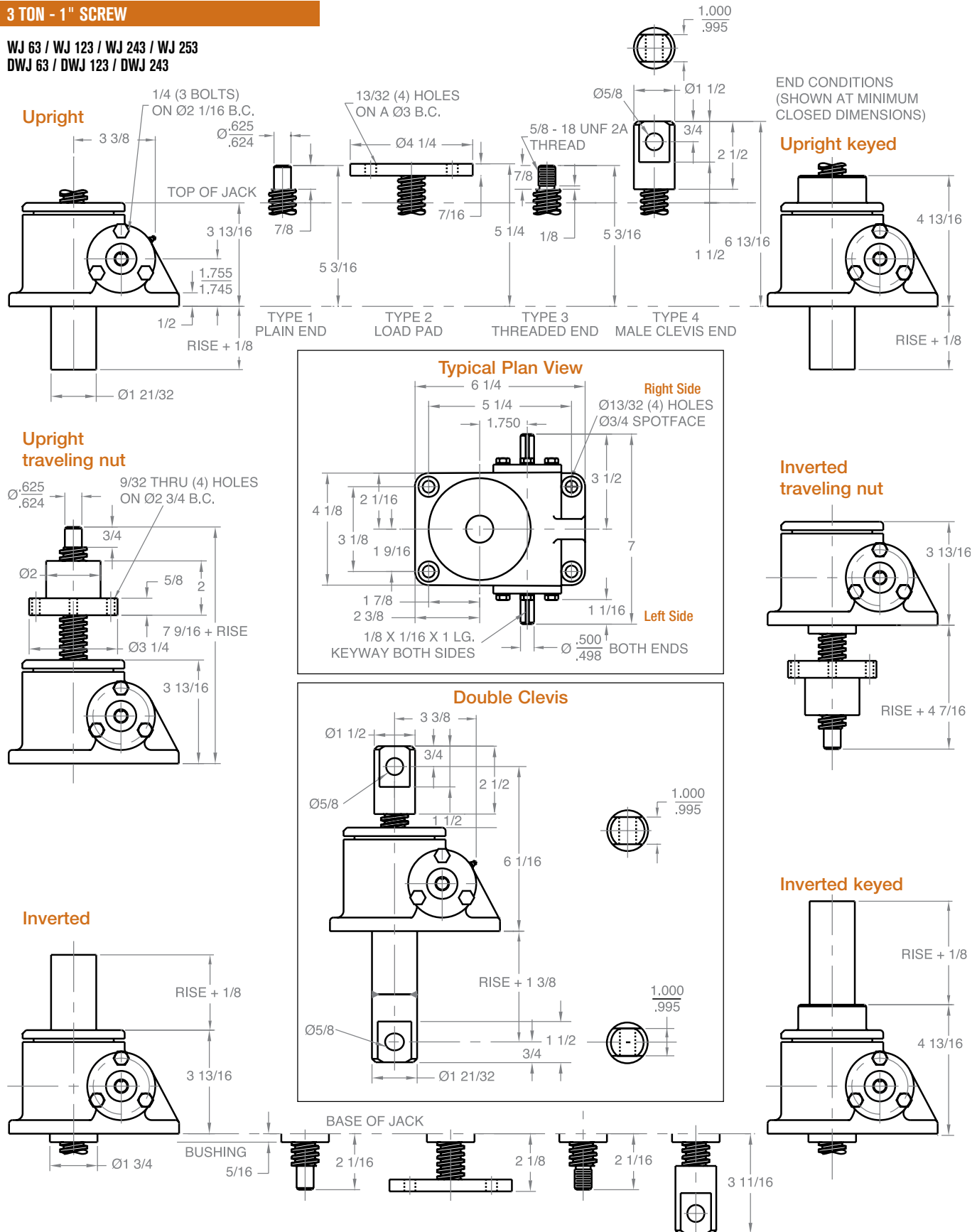

Note: Drawings are artist's conception — not for certification; dimensions are subject to change without notice. Minimum closed dimensions do not apply to upright keyed jacks.

MACHINE SCREW JACKS

5 TON - 1 1/2" SCREW

WJT 65 / DWJ 65
 WJT 125 / DWJ 125
 WJT 245 / DWJ 245
 WJT 255

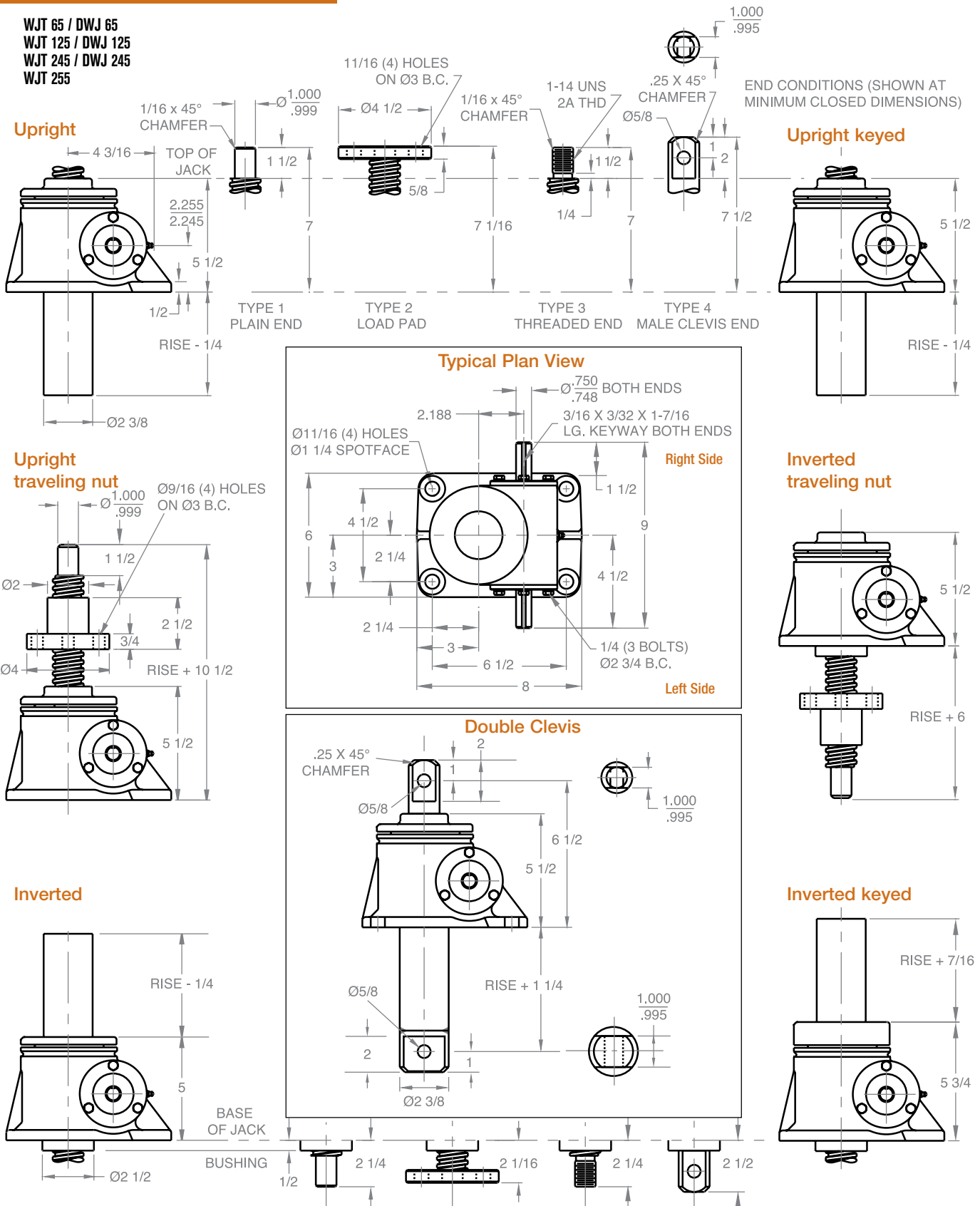

Note: Drawings are artist's conception — not for certification; dimensions are subject to change without notice.

MACHINE SCREW JACKS

10 TON - 2" SCREW

WJ 810 / DWJ 810
WJ 2410 / DWJ 2410
WJ 2510

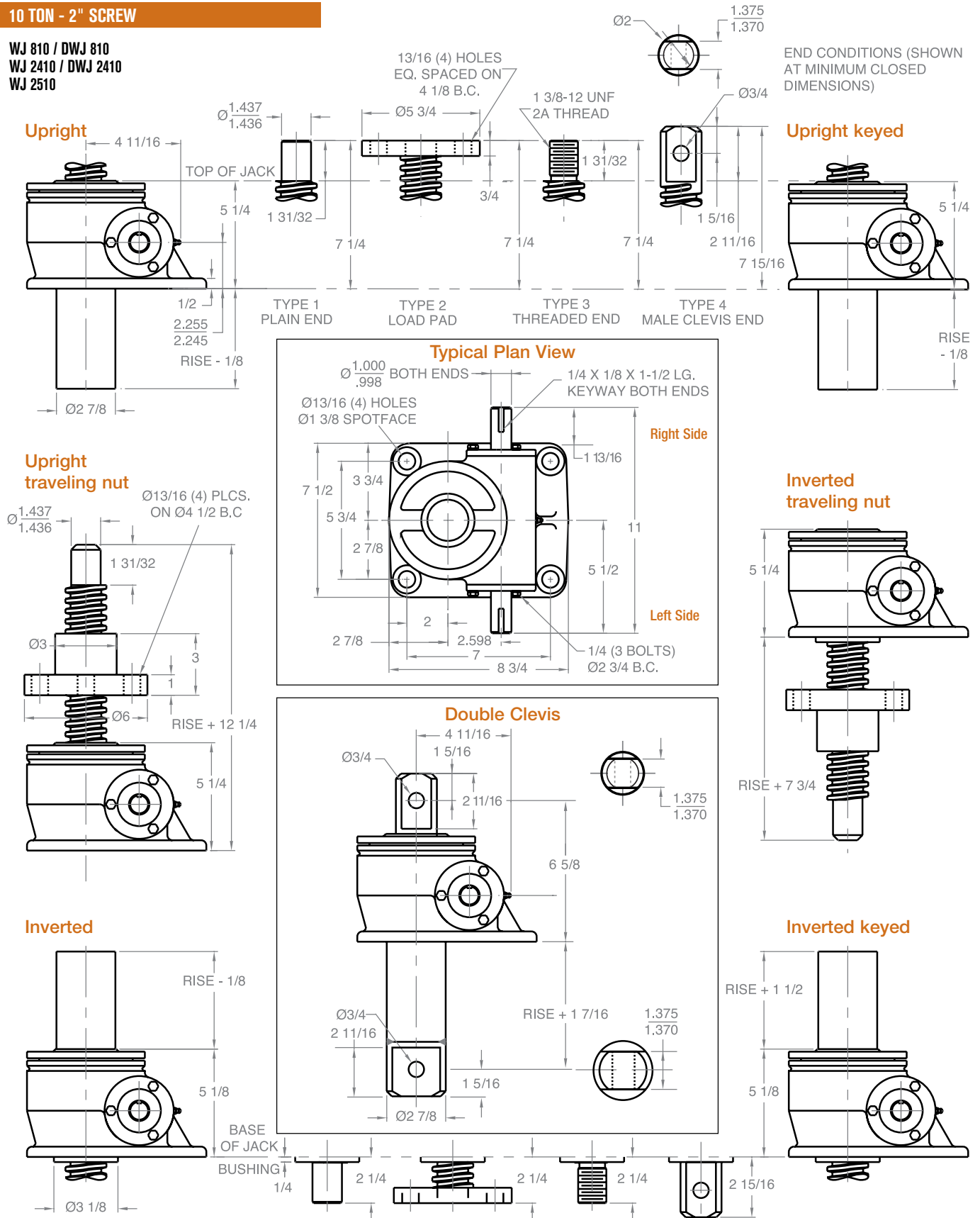

Note: Drawings are artist's conception — not for certification; dimensions are subject to change without notice.

MACHINE SCREW JACKS

15 TON - 2 1/4" SCREW

WJ 815 / DWJ 815
WJ 2415 / DWJ 2415
WJ 2515

Upright

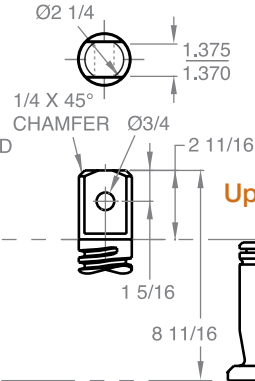
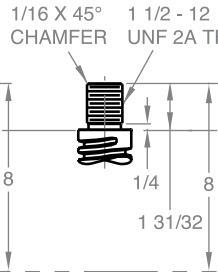
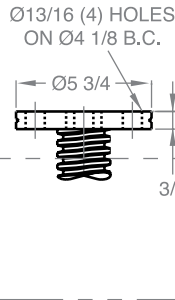
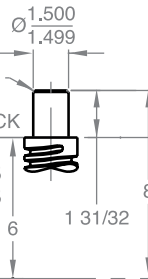
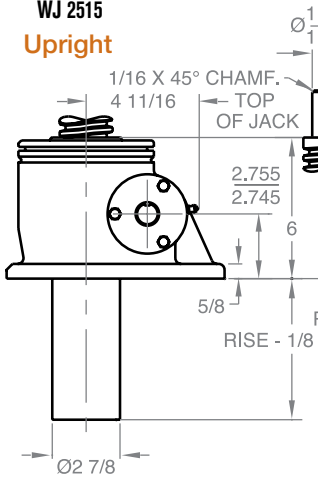

Upright keyed

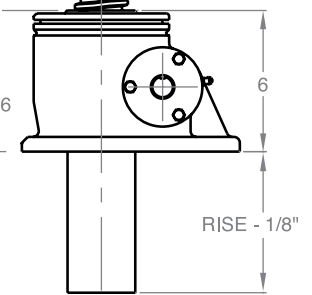

Typical Plan View

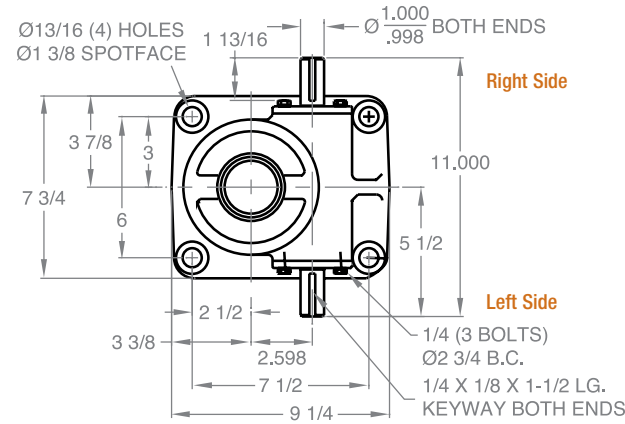

Upright traveling nut

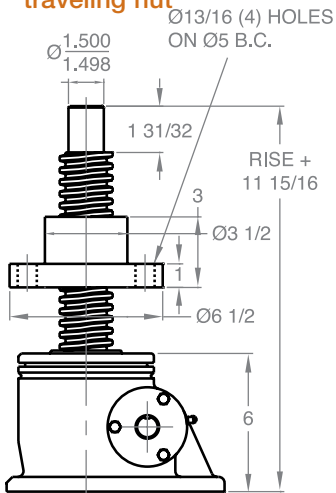

Inverted traveling nut

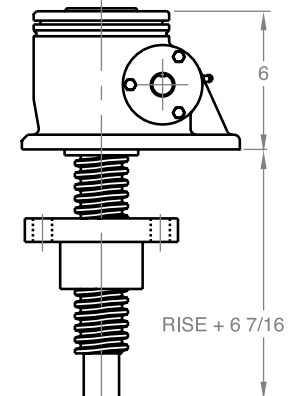

Inverted

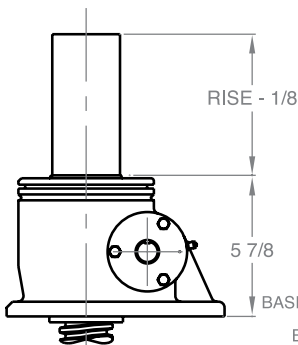

Double Clevis

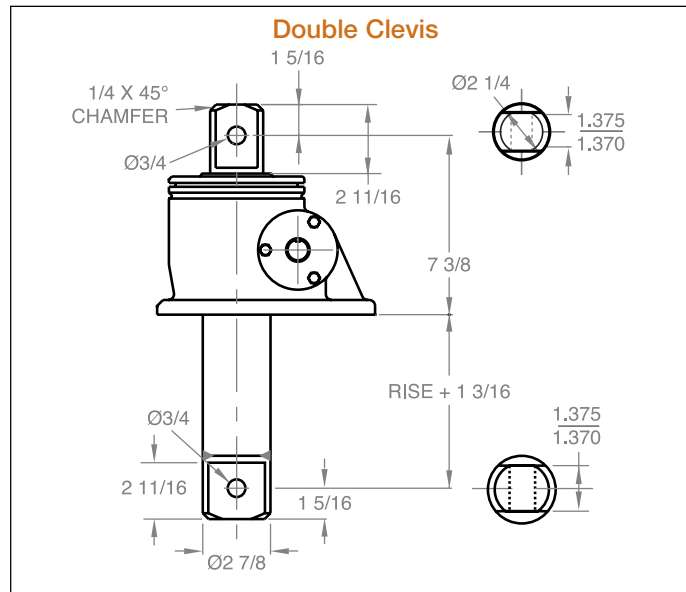

Inverted keyed

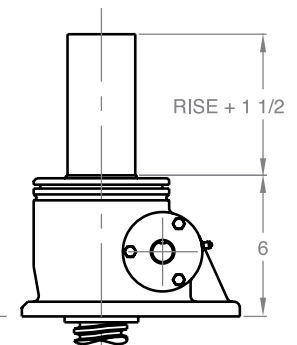

Note: Drawings are artist's conception — not for certification; dimensions are subject to change without notice.

MACHINE SCREW JACKS

20 TON - 2 1/2" SCREW

WJ 820 / DWJ 820
WJ 2420 / DWJ 2420
WJ 2520

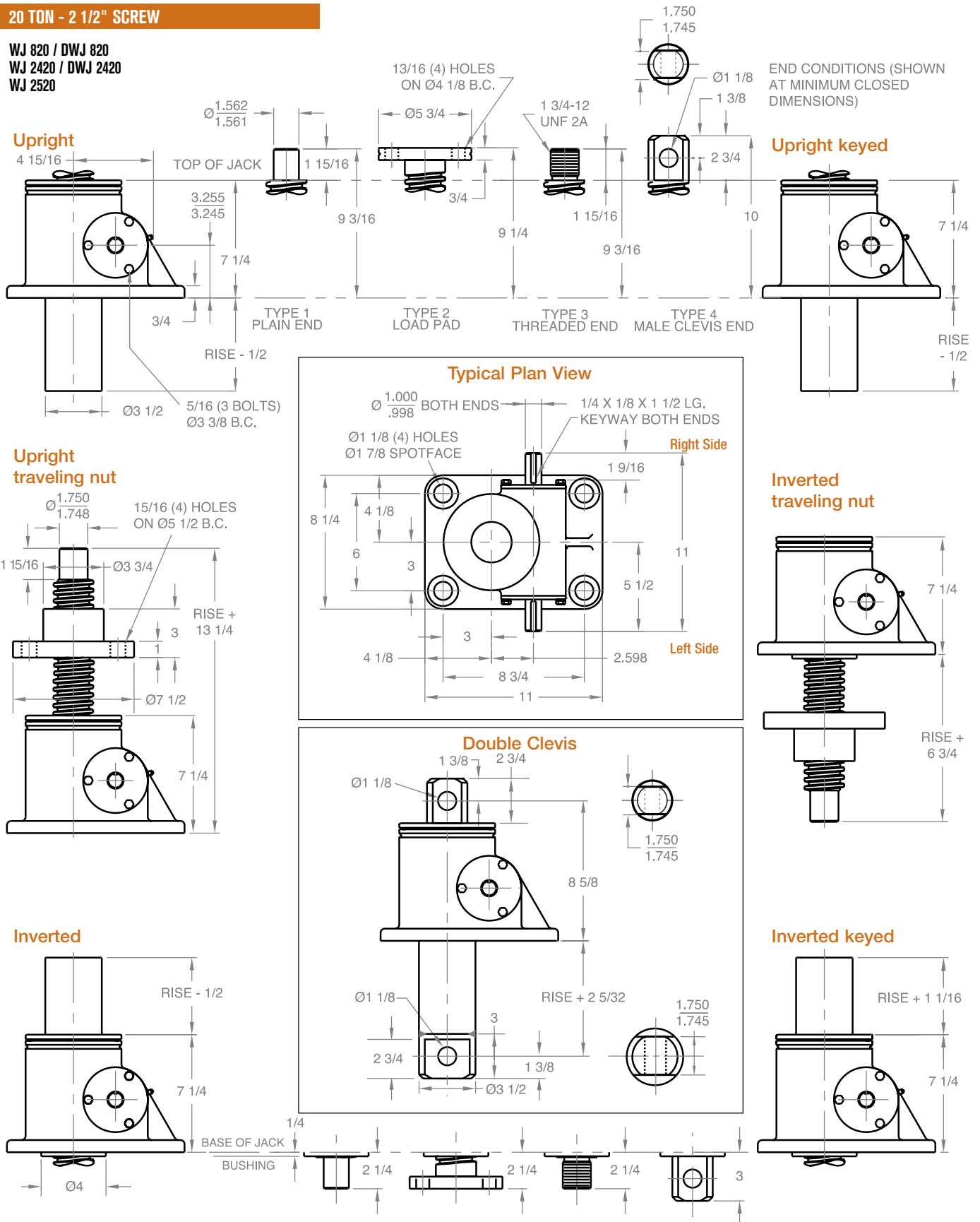

Note: Drawings are artist's conception — not for certification; dimensions are subject to change without notice.

MACHINE SCREW JACKS

25 TON - 3 3/8" SCREW

WJ 1125 / DWJ 1125
WJ 3225 / DWJ 3225

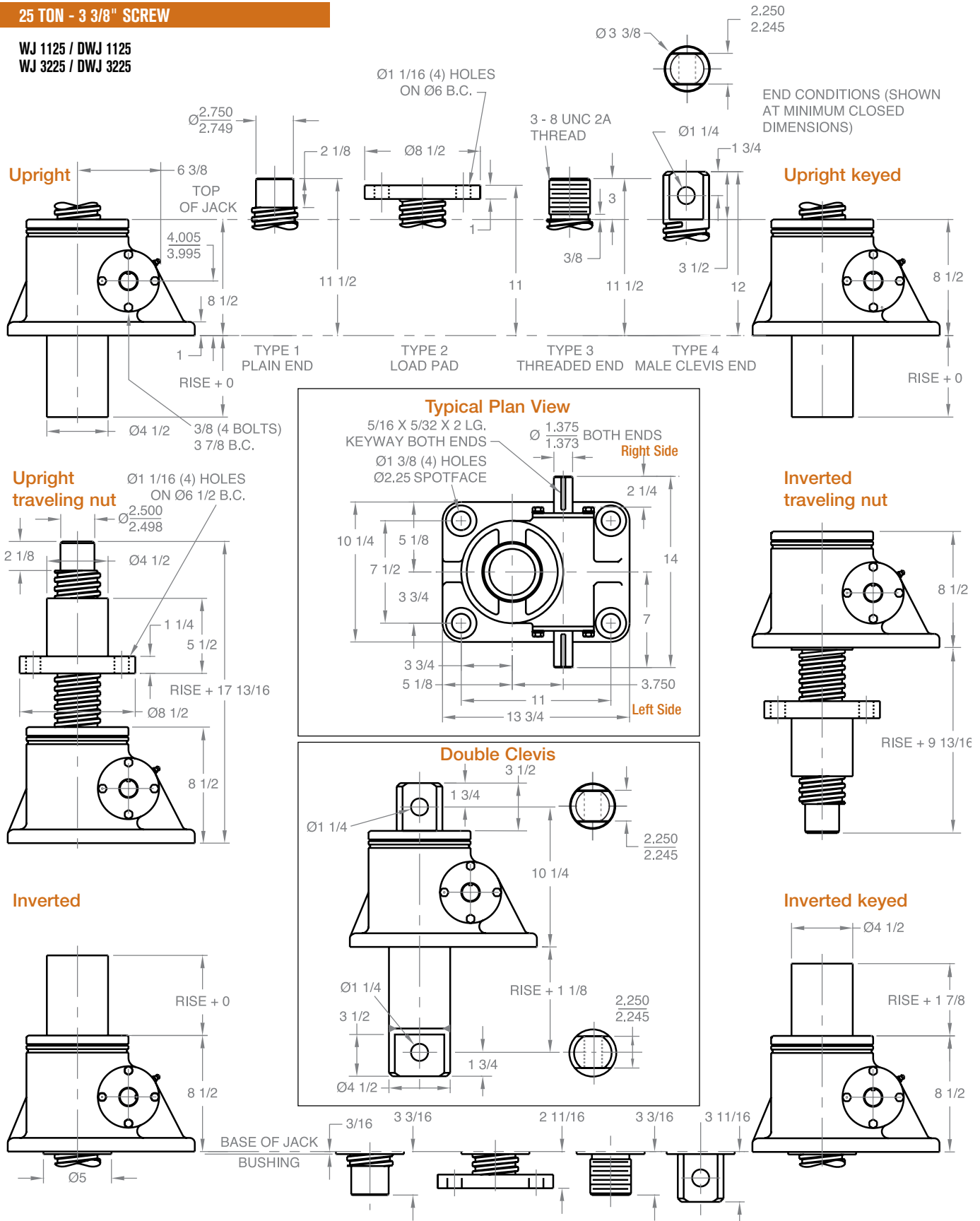

Note: Drawings are artist's conception — not for certification; dimensions are subject to change without notice.

MACHINE SCREW JACKS

30 TON - 3 1/2" SCREW

WJ 1130 / DWJ 1130
WJ 3230 / DWJ 3230

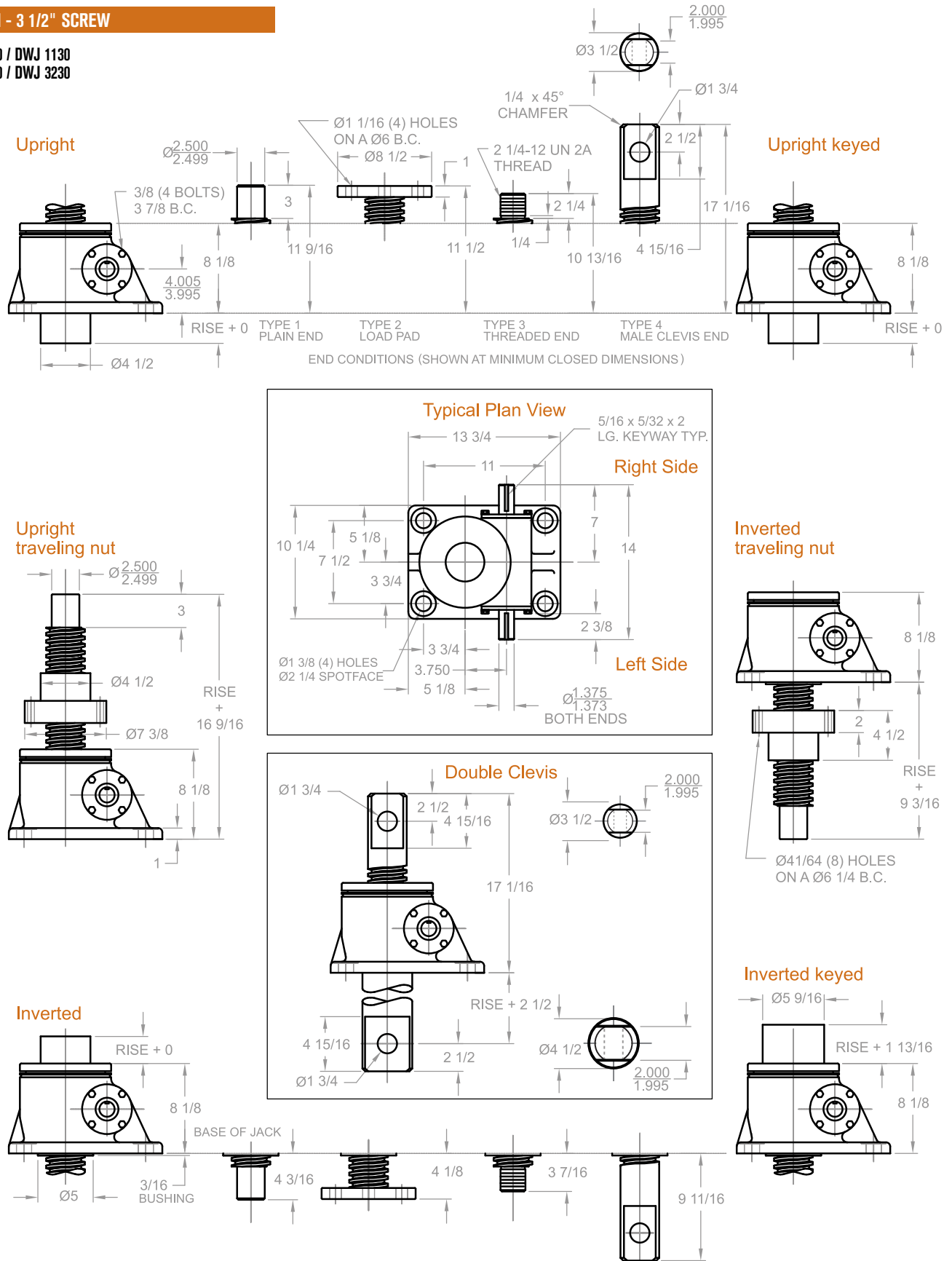

Note: Drawings are artist's conception — not for certification; dimensions are subject to change without notice.

MACHINE SCREW JACKS

35 TON - 3 3/4" SCREW

WJ 1135
WJ 3235

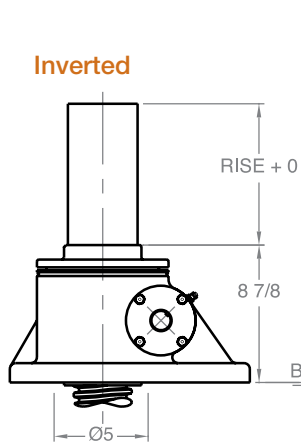
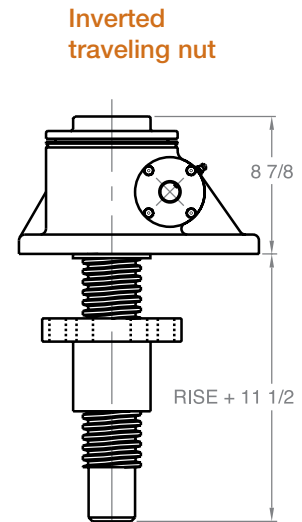
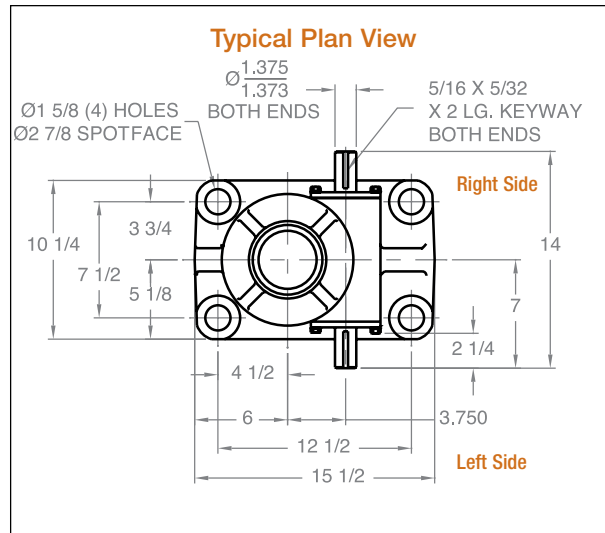
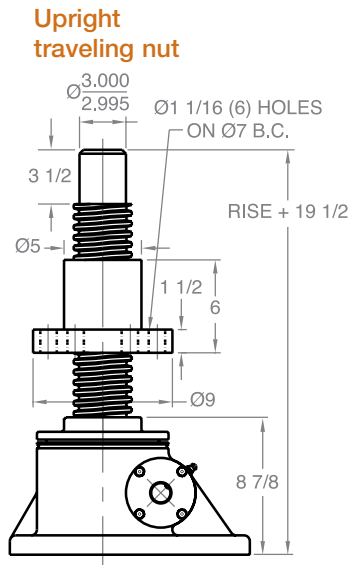
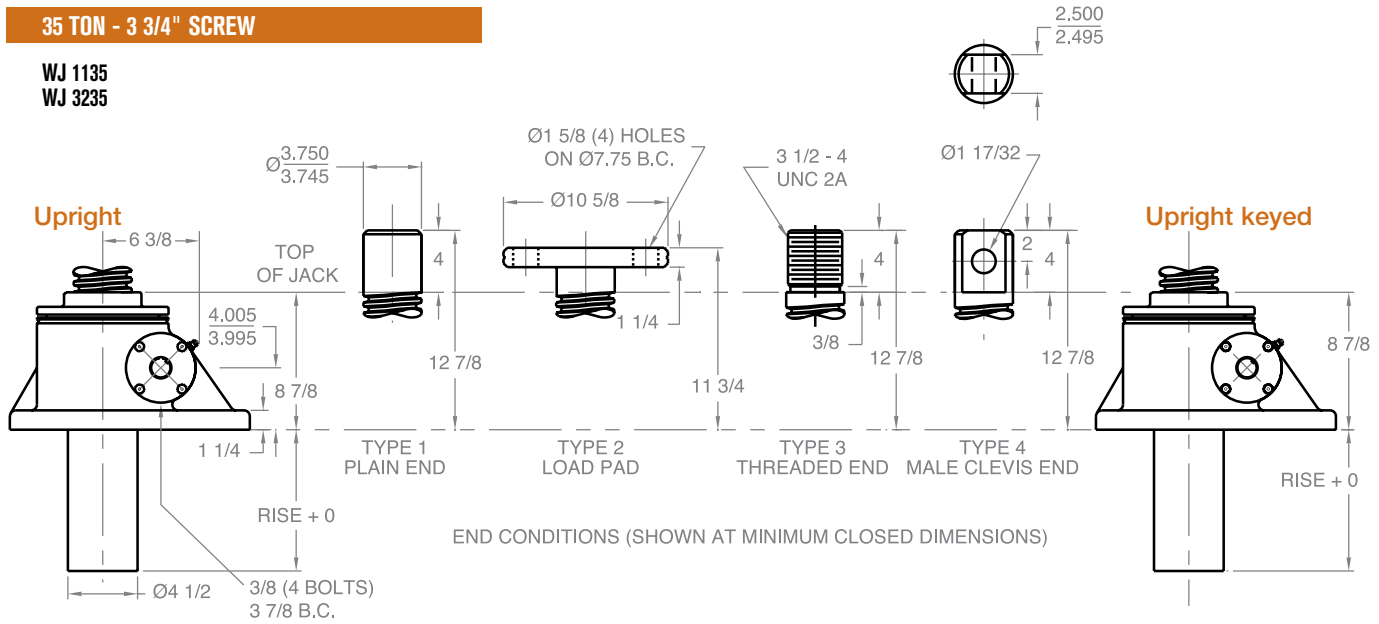

FOR DOUBLE CLEVIS DESIGN
CONTACT JOYCE/DAYTON

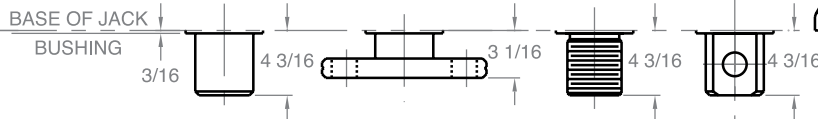
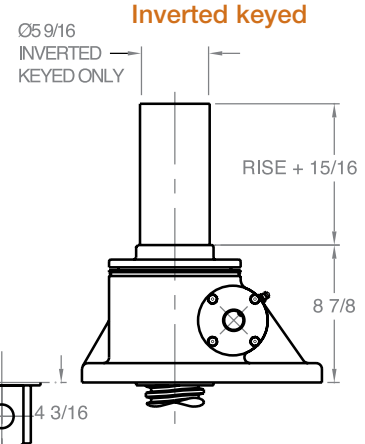

Note: Drawings are artist's conception — not for certification; dimensions are subject to change without notice.

MACHINE SCREW JACKS

50 TON - 4 1/2" SCREW

WJT 1150
WJT 3250

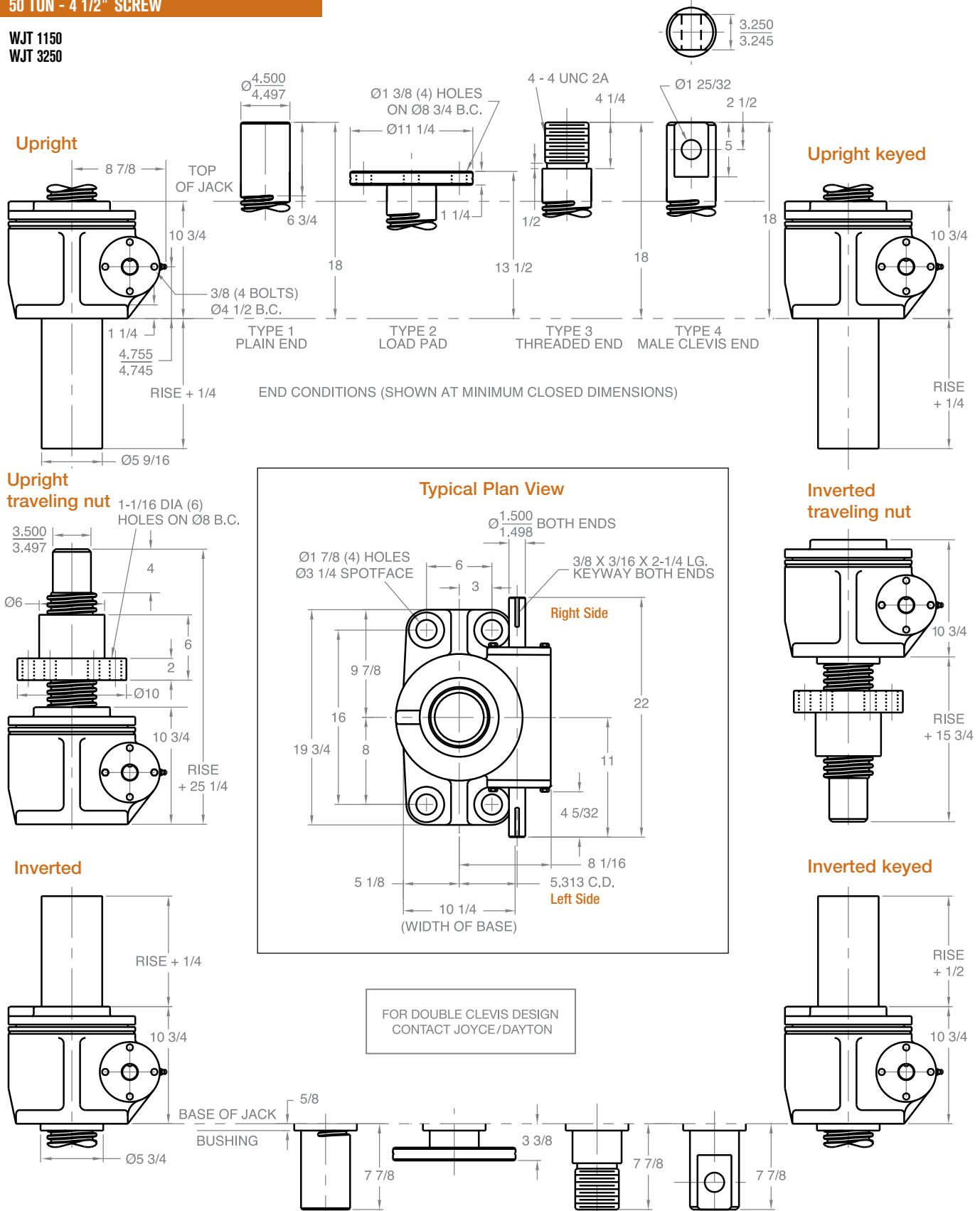

Note: Drawings are artist's conception — not for certification; dimensions are subject to change without notice.

MACHINE SCREW JACKS

50 TON REVERSE BASE - 4 1/2" SCREW

RWJT 1150
RWJT 3250

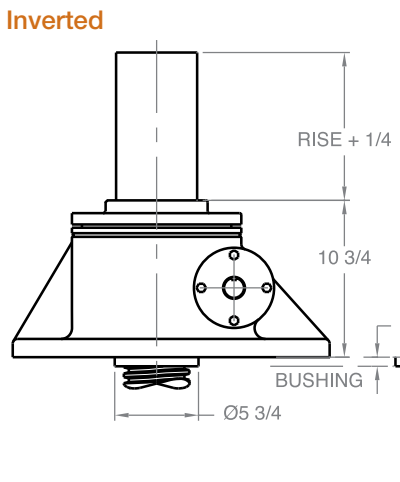
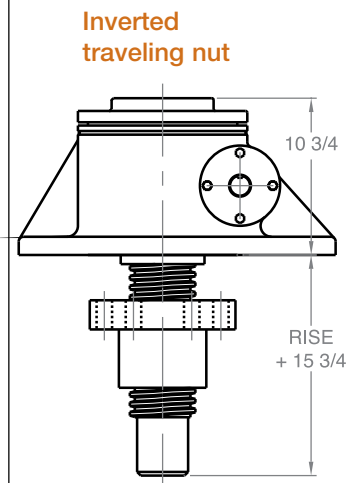
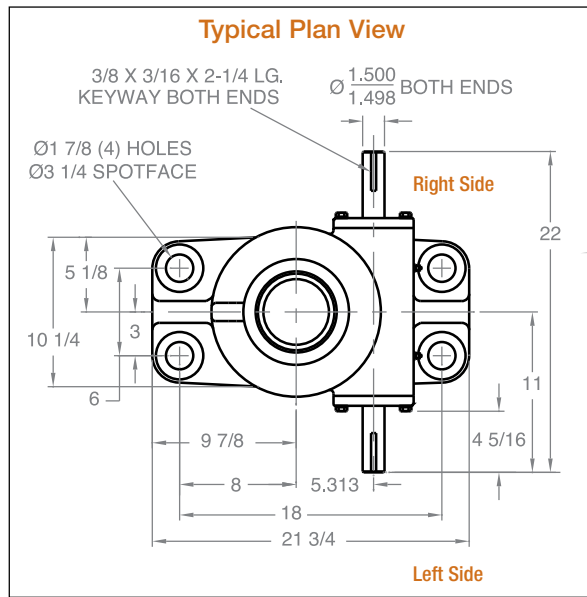
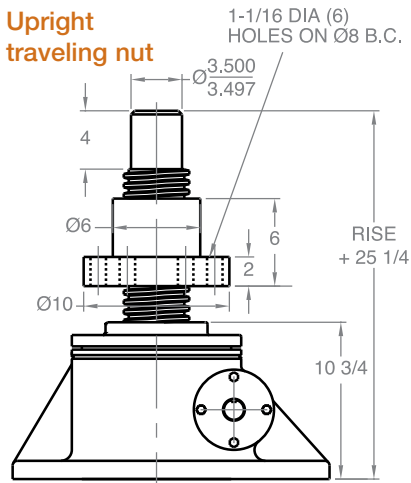
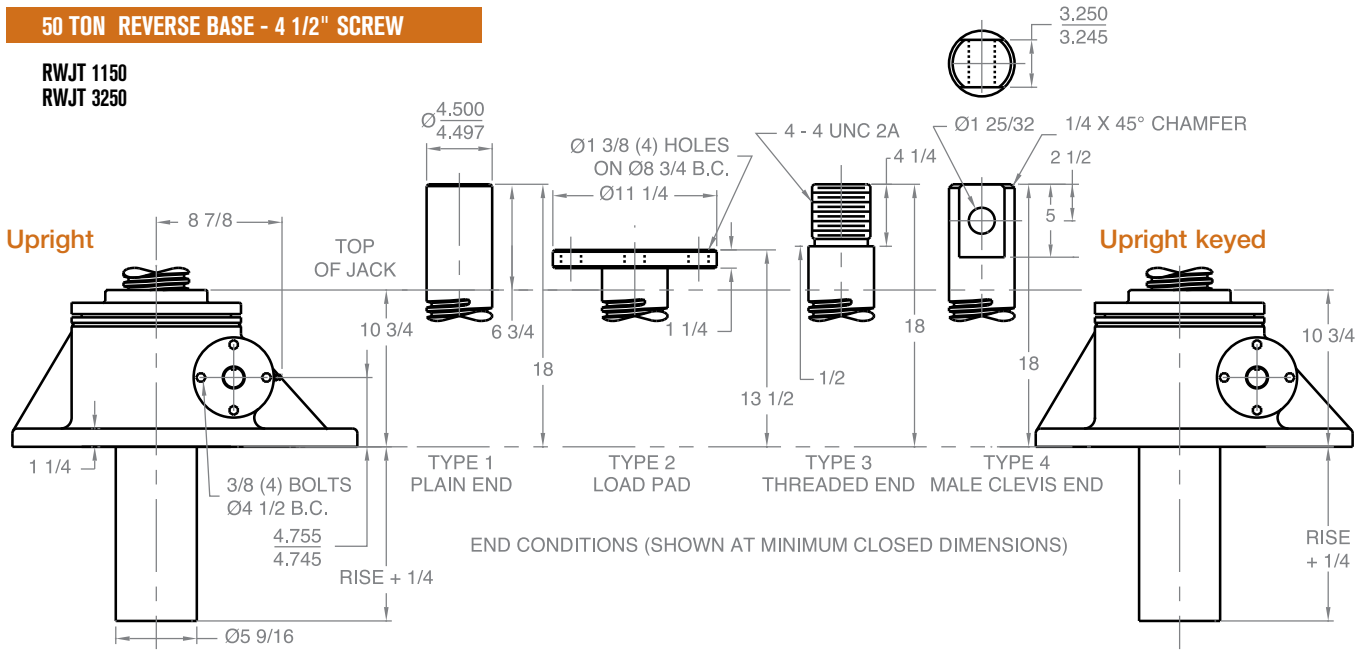

FOR DOUBLE CLEVIS DESIGN
CONTACT JOYCE/DAYTON

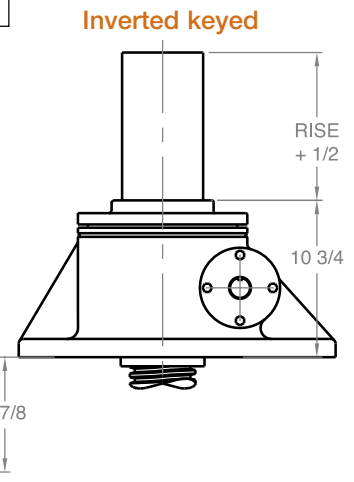

Note: Drawings are artist's conception — not for certification; dimensions are subject to change without notice.

MACHINE SCREW JACKS

100 TON - 6" SCREW

WJ 12100
WJ 36100

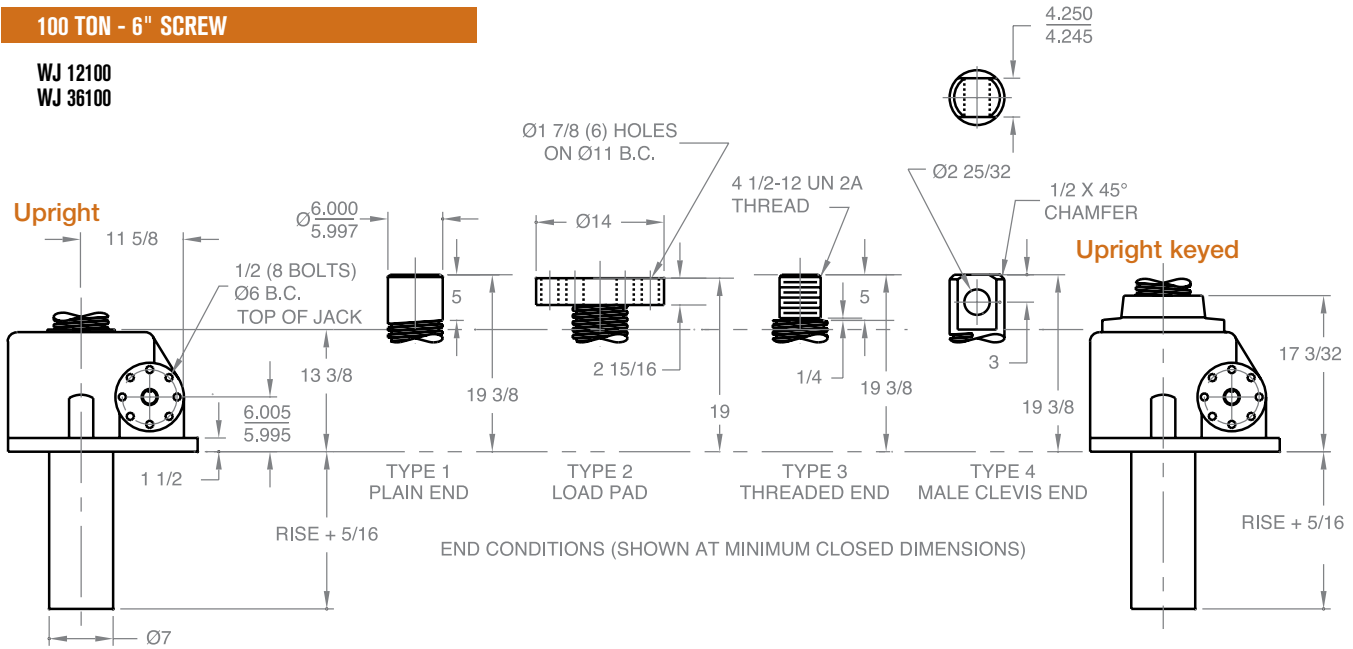

Upright traveling nut

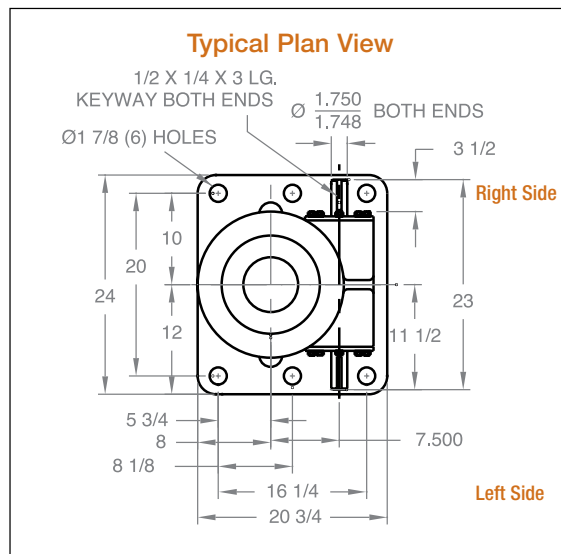
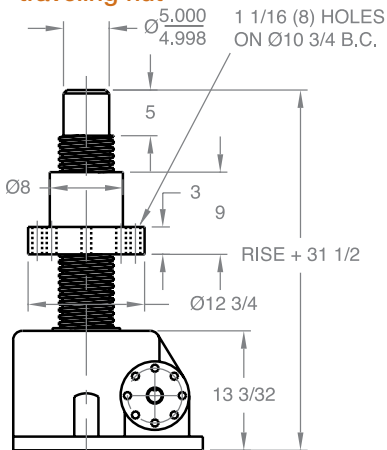

Inverted traveling nut

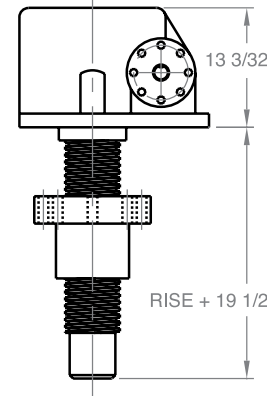

Inverted

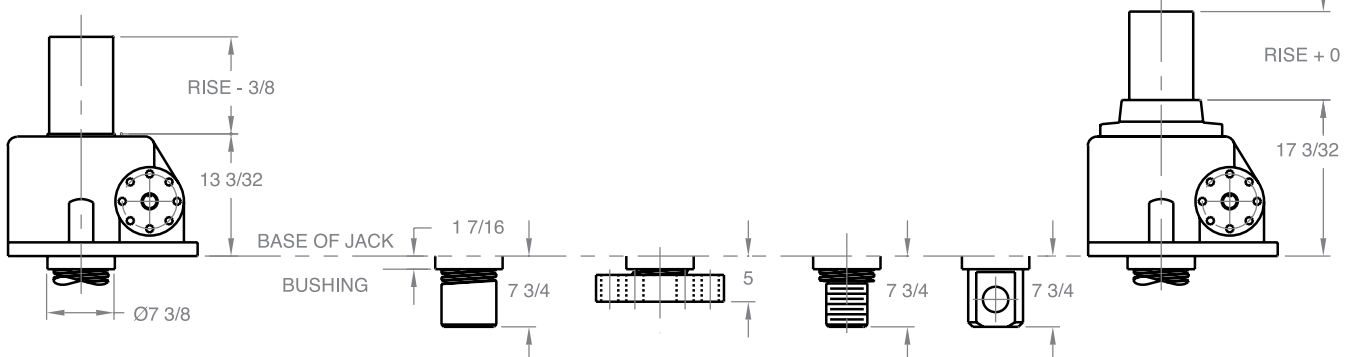

Note: Drawings are artist's conception — not for certification; dimensions are subject to change without notice. Minimum closed dimensions do not apply to upright keyed jacks.

MACHINE SCREW JACKS

250 TON - 9" SCREW

WJ 50250

Upright

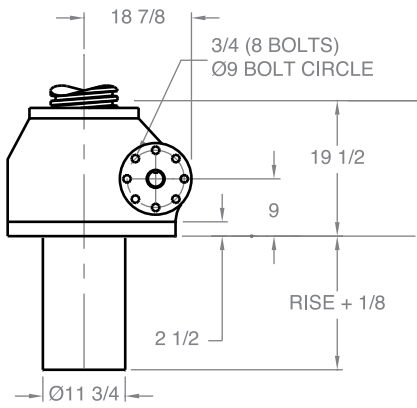

Ø2 3/4 (6) HOLES
ON Ø17 B.C.

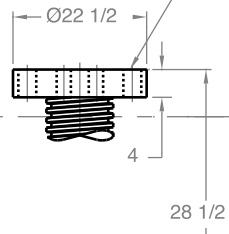

Upright keyed

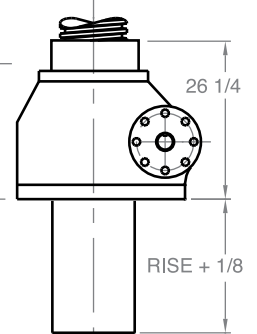

TOP OF JACK

TYPE 2
LOAD PAD

END CONDITION (SHOWN AT MINIMUM CLOSED DIMENSION)

Typical Plan View

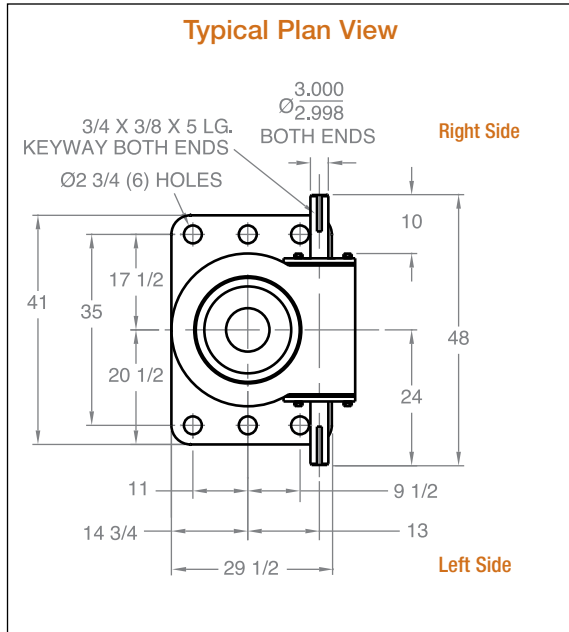

Inverted

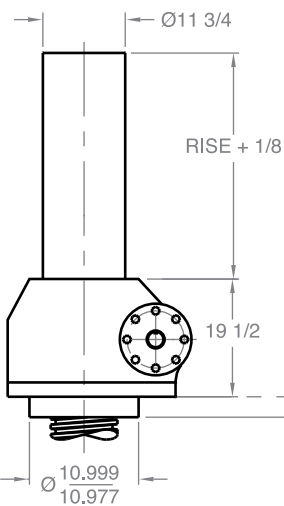

Inverted keyed

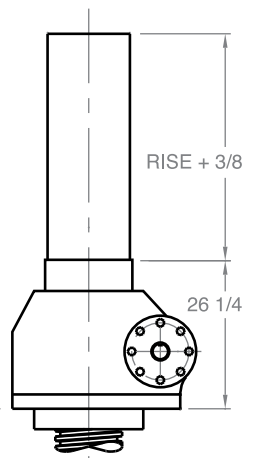

Note: Drawings are artist's conception — not for certification; dimensions are subject to change without notice. Minimum closed dimensions do not apply to upright keyed jacks.

MACHINE SCREW ComDRIVES®



Joyce machine screw ComDRIVES® combine a machine screw jack, motor and gear reducer into a single compact unit. ComDRIVES are available in 2-ton through 30-ton capacities. They provide travel speeds up to 35.1 inches per minute. ComDRIVES with single lead screws (CD) are self-locking; those with double lead screws (DCD) may require a brake motor or external locking device to hold position.

Four standard end conditions are available and ComDRIVES can be fitted with protective boots. Limit switches, anti-backlash devices, and other options are also available.

ComDRIVE Benefits:

- Can power an entire jacking system.
- Reduces the number of components that must be specified.
- Simplifies design.
- Reduces installation costs with only a single plate needed to mount the jack body.
- Reduces the number of couplings and shafts required in multi-jack systems.
- Standard 230/460 volt, 3-phase, 60 hertz motor included.

ComDRIVES can be specified without the motor. The reducer flange accepts standard NEMA motor frame sizes.

Joyce/Dayton can customize ComDRIVES to meet your specifications. Ask about larger size ComDRIVES.

Joyce/Dayton offers Machine Screw ComDRIVES in several designs including:

- Translating
- Keyed for non-rotation
- Keyed for traveling nut (KFTN)
- Double clevis
- Trunnion mount

A guide for ordering is on pages 46 and 47.

MACHINE SCREW ComDRIVES® ORDERING INFORMATION

Instructions: Select a model number from this chart.

2-Ton	3-Ton	5-Ton	10-Ton	15-Ton	20-Ton	25-Ton	30-Ton
CD62 CD122 CD242	CD63 CD123 CD243	CD65 CD125 CD245	CD810 CD2410	CD815 CD2415	CD820 CD2420	CD1125 CD3225	CD1130 CD3230
DCD62* DCD122* DCD242*	DCD63* DCD123* DCD243*	DCD65* DCD125* DCD245*	DCD810* DCD2410*	DCD815* DCD2415*	DCD820* DCD2420*	DCD1125* DCD3225*	DCD1130* DCD3230*

Important Note: *Not self-locking, may lower under load. Brake motors or external locking systems are recommended.

DCD: Double lead screw.

(For 25:1 ratio, contact Joyce/Dayton.)

Sample Part Number: CD65U2S-18.50-P1AB-STDX-B

Jack Configuration

U=Upright I=Inverted

End Conditions

1=T1 (plain end)
2=T2 (load pad)
3=T3 (threaded end)
4=T4 (male clevis)

Left Side Shaft Code
(see below)

XXXX=Remove
STDX=Standard

For optional shaft codes, see page 47.

Right Side Shaft Code
(see below)

XXXX=Remove
STDX=Standard

For optional shaft codes, see page 47.

Additional Options

X=Standard Jack, no additional options

S=Additional Specification Required (comment as necessary)

Anti-Backlash p. 180
A=Split Nut
A90=A90 Design
A95=A95 Design

Protective Boots pp. 170-172
B=Protective Boot
D=Dual Protective Boot

Finishes p. 179
F1=Do Not Paint
F2=Epoxy Paint
F3=Outdoor Paint Process

Motor Options
M1=Less Motor
M2=Brake Motor
M3=Single Phase Motor (120VAC)
M4=50Hz Motor

Grease/Seals
H1=High Temperature Operation
H2=Food Grade

Screw Stops
Extending and retracting stops are standard on ComDRIVES.

• Specify as many options as needed

ComDRIVE® Rise

Rise is travel expressed in inches and not the actual screw length. When companion jacks are ordered with the ComDRIVE®, their screws are lengthened to match the ComDRIVE®.

Jack Designs

S=Translating K=Keyed for Non Rotation N=Traveling Nut D=Double Clevis R=KFTN Trunnion*
T=Trunnion*

*Standard trunnion mounts available on 2-ton through 20-ton jacks. (See page 173)

MACHINE SCREW ComDRIVES® SHAFT CODES

Instructions: Select the appropriate shaft codes for both right and left hand shafts. One shaft code must be specified for each side of the ComDRIVE®.

Screw Stops (p. 10) and Boots (pp. 170-172)
 Extending and retracting screw stops are standard on ComDRIVES. When boots are added to ComDRIVES, the closed height of the unit may be increased.

Mechanical Counters (p. 177)
 CNT0=0.001" Increments
 Note: Contact Joyce/Dayton for availability and options.



G geared Potentiometers (p. 176)
 POTA=0-10V (IP65)
 POTB=4-20MA (IP65)
 POTC=0-10V w/2 switches*
 POTD=4-20MA w/2 switches* *Optional IP65 rating available



Encoders and Electronic Limit Switches
 ENCX=Encoder (p. 178)
 ELS2=2 Position Electronic Switch (p. 174)
 ELS4=4 Position Electronic Switch (p. 174)
 ELS6=6 Position Electronic Switch (p. 174)



ComDRIVE Reducers (pp. 49-57)

Ordering Example: P2AC Motor code from chart at right

Code	Mounting Positions				Ratio
	P1	P2	P3	P4	
Left Side Shaft Options					5:1 Code A
Right Side Shaft Options					7.5:1 Code B
					10:1 Code C

Motors

Size	Code
1/4 HP	K
1/3 HP	A
1/2 HP	B
3/4 HP	C
1 HP	D
1-1/2 HP	E
2 HP	F
3 HP	L
5 HP	G
7-1/2 HP	H
10 HP	I
15 HP	J

All standard motors are 3-phase, 208-230/460 VAC or 230/460 VAC. Other motor options are available including international voltages, and single phase AC. Specify the appropriate motor size from the chart above. Refer to the "Additional Options" chart on the preceding page as needed. Brake motors are required for ball screw ComDRIVES®. Contact Joyce/Dayton for other options.

Mechanical Limit Switches (pp. 174-175)

Ordering Example: LA13

Models		Number of DPDT Switches (see p. 175)	Available Positions							
Model	Code		1	2*	3	4	5	6*	7	8
LS7-402	LI	NOTE: Will always be 0 for LS7 models								
LS8-402	LA									
LS8-404	LB									
LS9-502	LC									
LS9-503	LD									
LS9-504	LE									
LS9-505	LF									
LS9-506	LG									
LS9-507	LH									

• 2, 3, 5, 10, 15, and 20 ton ComDRIVES are available with positions #1, #3, and #5.
 • 25 and 30 ton ComDRIVES are available with positions #1, #4, #7 and #8.
 * These positions are not standard. Contact Joyce/Dayton with your requirements.

MACHINE SCREW ComDRIVES[®] COLUMN LOADING

Machine Screw ComDRIVE[®] Column Loading Chart

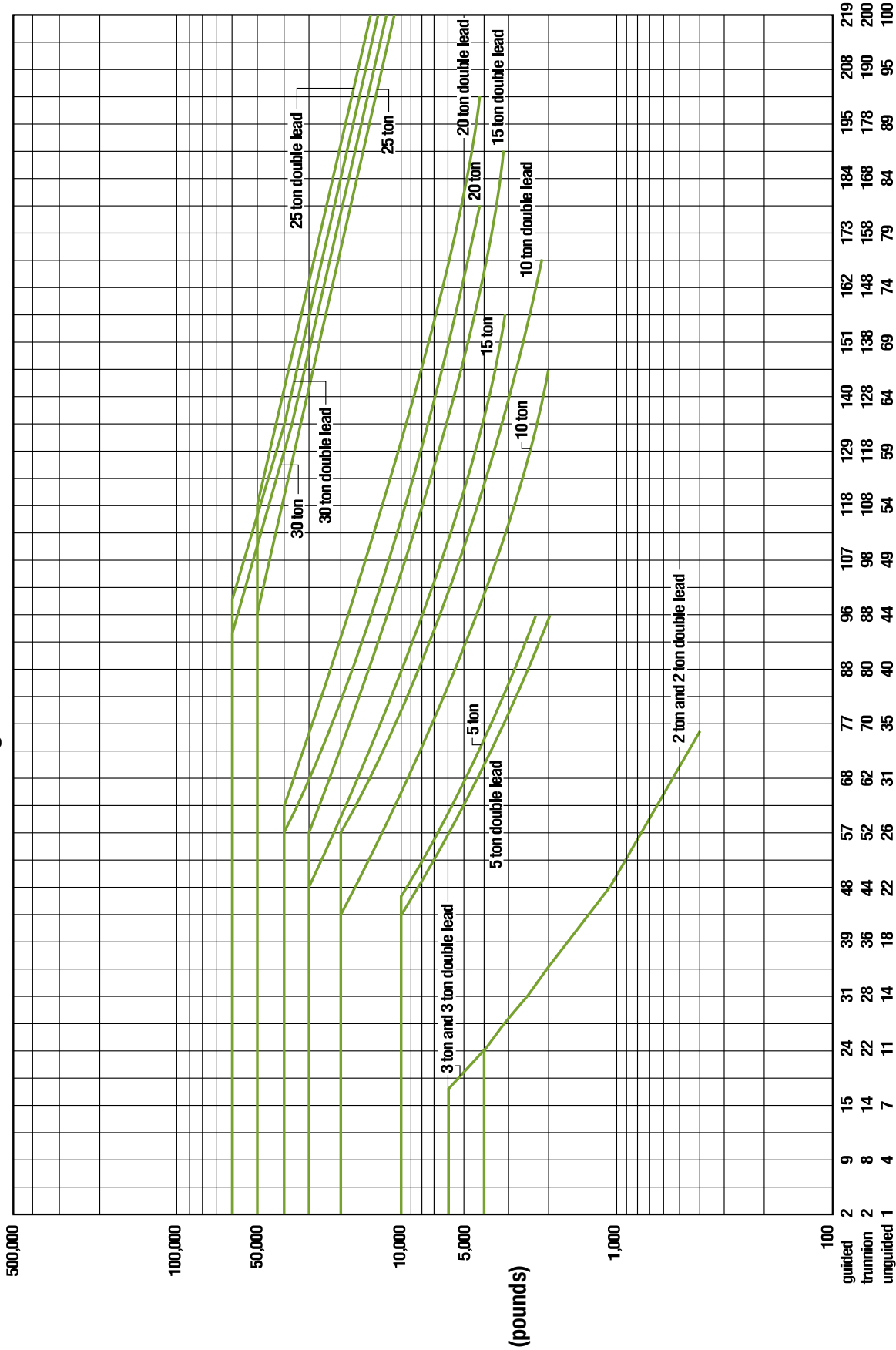

Screw Length (inches)

This chart includes a 2:1 Factor-of-Safety based on the Euler-Johnson equation for column loading (Oberg, Erik et al: Machinery's Handbook, 24th Edition, c. 1992 Industrial Press Inc.) The horizontal portion of each line represents the jack's maximum dynamic capacity. Under static conditions, these lines can be exceeded. Please contact factory for assistance.

MACHINE SCREW ComDRIVES[®] SPECIFICATIONS

2 Ton Model Number		CD62			CD122		CD242			DCD62			DCD122		DCD242		
Reducer Ratio		5	7 1/2	10	5	7 1/2	5	7 1/2	10	5	7 1/2	10	7 1/2	5	7 1/2	10	
Travel Speed IPM		13.88	9.50	7.04	6.94	4.75	3.47	2.38	1.76	27.75	19.00	14.08	9.50	6.94	4.75	3.52	
Lifting Capacity, Lbs.	1/3 HP	1,865	2,650	3,500	3,350	4,000	4,000	4,000	4,000	1,300	1,850	2,450	3,300	3,830	4,000	4,000	
	1/2 HP	2,875	4,000	4,000	4,000					2,000	2,825	3,720	4,000	4,000			
	3/4 HP	4,000								3,060	4,000						
3 Ton Model Number		CD63			CD123		CD243			DCD63			DCD123		DCD243		
Reducer Ratio		5	7 1/2	10	5	7 1/2	5	7 1/2	10	5	7 1/2	10	7 1/2	5	7 1/2	10	
Travel Speed IPM		13.88	9.50	7.04	6.94	4.75	3.47	2.38	1.76	27.75	19.00	14.08	9.50	6.94	4.75	3.52	
Lifting Capacity, Lbs.	1/3 HP	1,910	2,700	3,555	3,425	4,790	5,610	6,000	6,000	1,335	1,890	2,485	3,350	3,925	5,415	6,000	
	1/2 HP	2,920	4,095	5,380	5,235	6,000	6,000			2,045	2,865	3,765	5,085	6,000	6,000		
	3/4 HP	4,430	6,000		6,000					3,100	4,340		6,000				
5 Ton Model Number		CD65			CD125		CD245			DCD65			DCD125		DCD245		
Reducer Ratio		5			10		10			5			10		10		
Travel Speed IPM		20.81			10.56		5.28			27.75			14.08		7.04		
Lifting Capacity, Lbs.	1 HP	3,760			6,980		10,000			3,320			6,170		10,000		
	1 1/2 HP	5,755								5,085							
	2 HP	7,750								6,845							
10 Ton Model Number		CD810			CD2410			DCD810			DCD2410						
Reducer Ratio		5			10			5			10			5			
Travel Speed IPM		20.81			10.56			6.94			27.76			14.09			
Lifting Capacity, Lbs.	1 HP	3,680			7,070			9,000			16,760			3,150			
	1 1/2 HP	5,760						14,090			4,925			12,050			
	2 HP	7,840						19,165			6,700			16,390			
	3 HP	12,150			20,000			20,000			20,000			10,385			
	5 HP	20,000									17,580						
15 Ton Model Number		CD815			CD2415			DCD815			DCD2415						
Reducer Ratio		5			10			5			10			5			
Travel Speed IPM		20.81			10.56			6.94			27.76			14.09			
Lifting Capacity, Lbs.	1 HP	3,140			6,200			7,535			14,385			2,715			
	1 1/2 HP	5,035						12,085			4,350			10,450			
	2 HP	6,925						16,620			5,990			14,375			
	3 HP	10,850			20,425			26,040			30,000			9,380			
	5 HP	18,515						30,000			16,010			17,665			
20 Ton Model Number		CD820			CD2420			DCD820			DCD2420						
Reducer Ratio		5			10			5			10			5			
Travel Speed IPM		20.81			10.56			6.94			27.76			14.09			
Lifting Capacity, Lbs.	1 HP	2,715			5,570			6,520			12,920			2,265			
	1 1/2 HP	4,475						10,745			3,730			8,960			
	2 HP	6,235						14,965			5,195			12,475			
	3 HP	9,880			18,785			23,715			40,000			8,235			
	5 HP	17,000						40,000			14,175			15,660			
25 Ton Model Number		CD1125			CD3225			DCD1125			DCD3225						
Reducer Ratio		5			10			5			10			5			
Travel Speed IPM		20.79			10.55			6.93			35.12			17.82			
Lifting Capacity, Lbs.	3 HP	9,050			17,165			20,390			36,800			7,385			
	5 HP	15,700			29,420			35,390			50,000			12,815			
	7 1/2 HP	23,930			45,755			50,000						19,530			
	10 HP	32,625			50,000									26,625			
	15 HP	49,410												40,325			
30 Ton Model Number		CD1130			CD3230			DCD1130			DCD3230						
Reducer Ratio		5			10			5			10			5			
Travel Speed IPM		20.82			10.57			6.94			35.12			17.82			
Lifting Capacity, Lbs.	3 HP	9,435			17,540			21,260			37,620			7,535			
	5 HP	16,100			29,815			36,280			60,000			12,885			
	7 1/2 HP	24,335			46,170			54,840						19,430			
	10 HP	33,040			60,000			60,000						26,385			
	15 HP	49,845												39,800			

Important Note: DCD models may lower under load. Brake motors or external locking systems are recommended.

MACHINE SCREW ComDRIVES®

2 TON - 1" SCREW

CD 62 / DCD 62
 CD 122 / DCD 122
 CD 242 / DCD 242

Upright

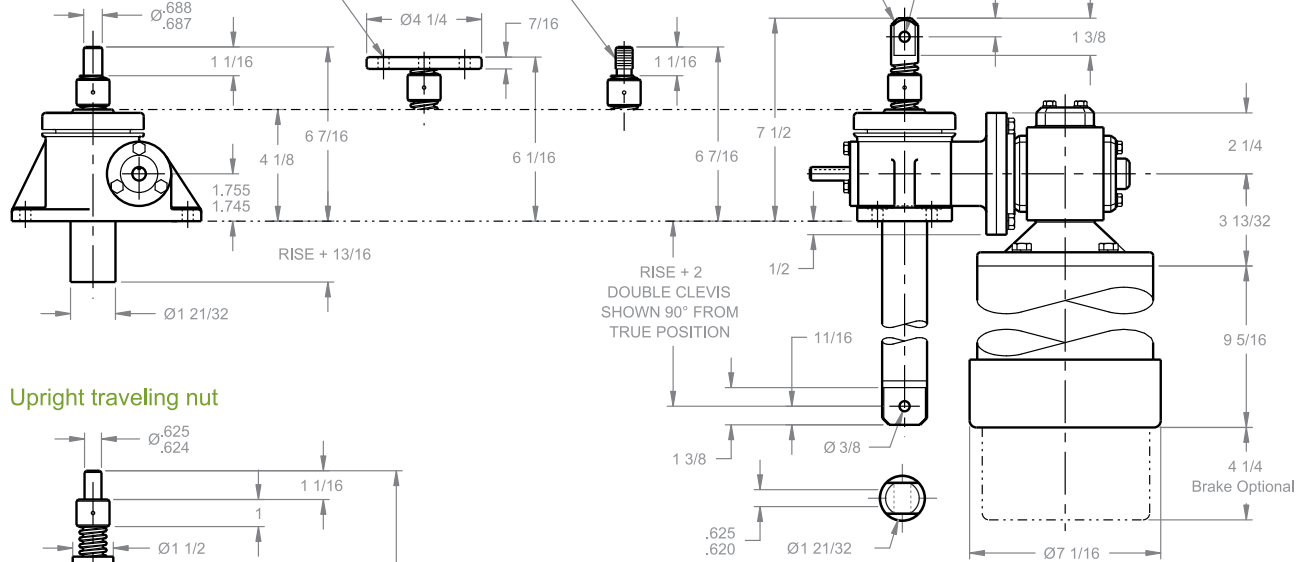

Upright traveling nut

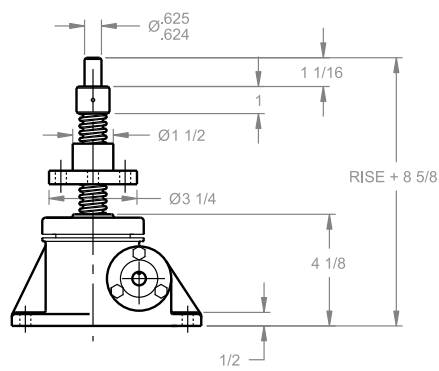

Inverted traveling nut

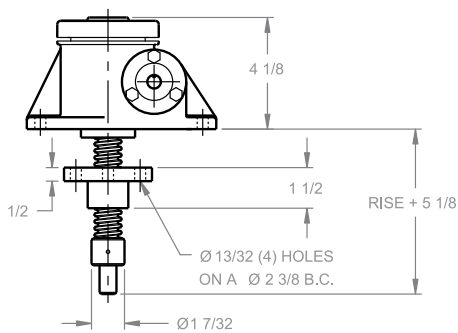

Inverted

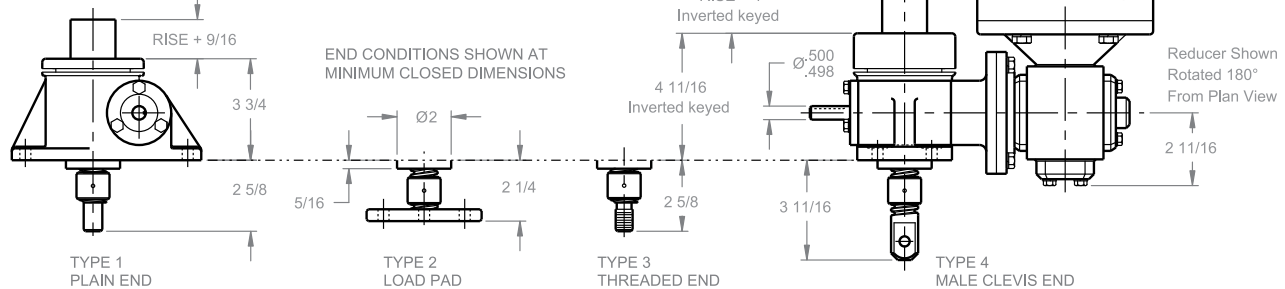

NOTE: FOR LIFTING CAPACITIES SEE PAGE 49

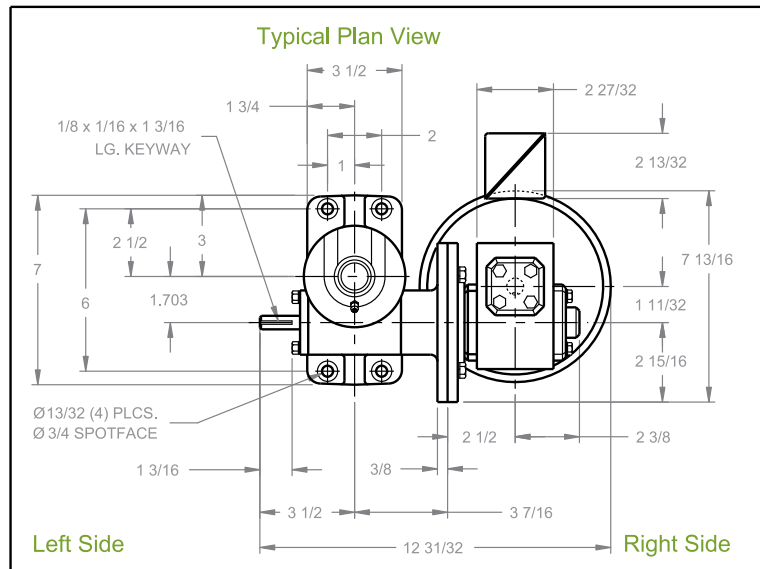

Note: Drawings are artist's conception — not for certification; dimensions are subject to change without notice.

MACHINE SCREW ComDRIVES®

3 TON - 1" SCREW

CD 63 / DCD 63
 CD 123 / DCD 123
 CD 243 / DCD 243

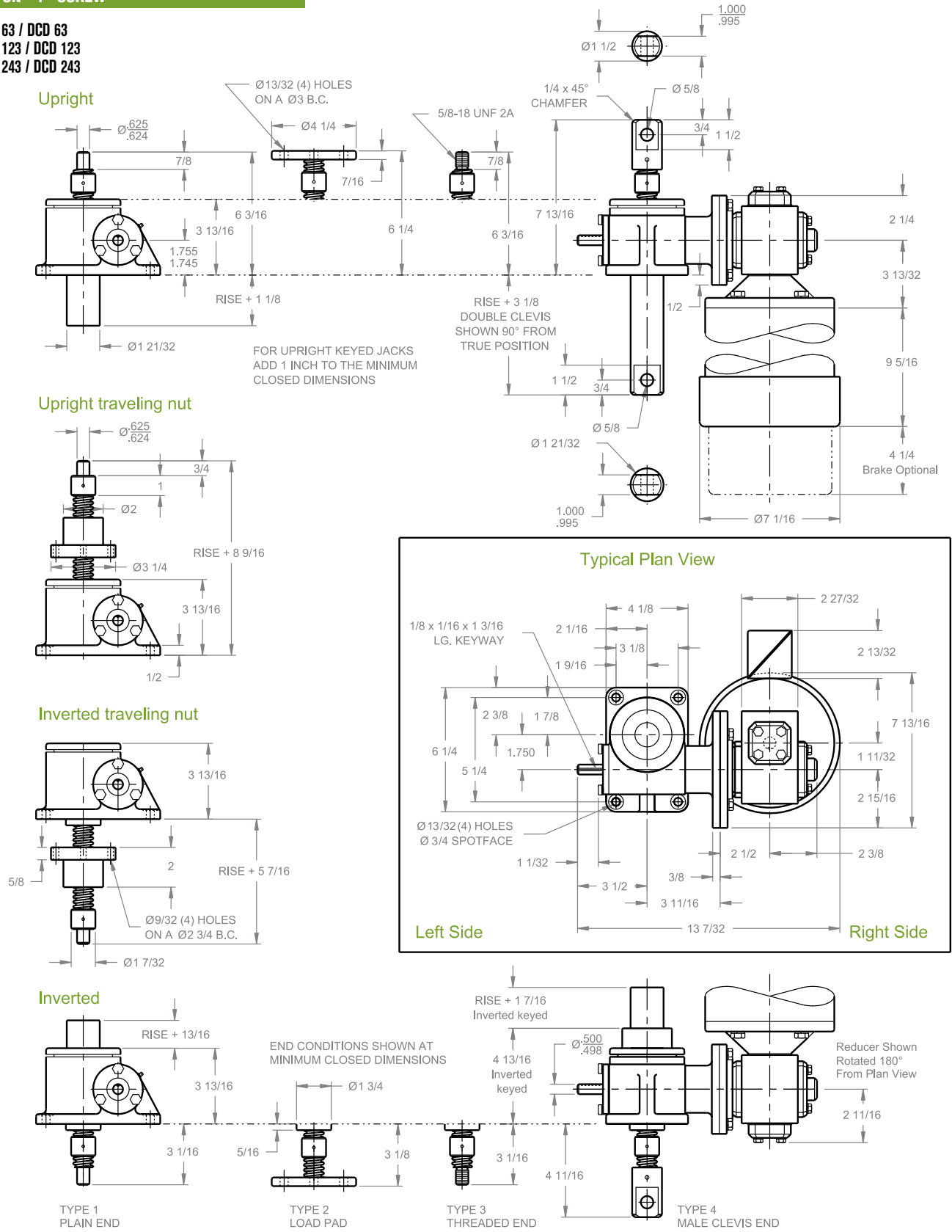

NOTE: FOR LIFTING CAPACITIES SEE PAGE 49

Note: Drawings are artist's conception — not for certification; dimensions are subject to change without notice.

MACHINE SCREW ComDRIVES®

10 TON - 2" SCREW

CD 810 / DCD 810
CD 2410 / DCD 2410

Upright

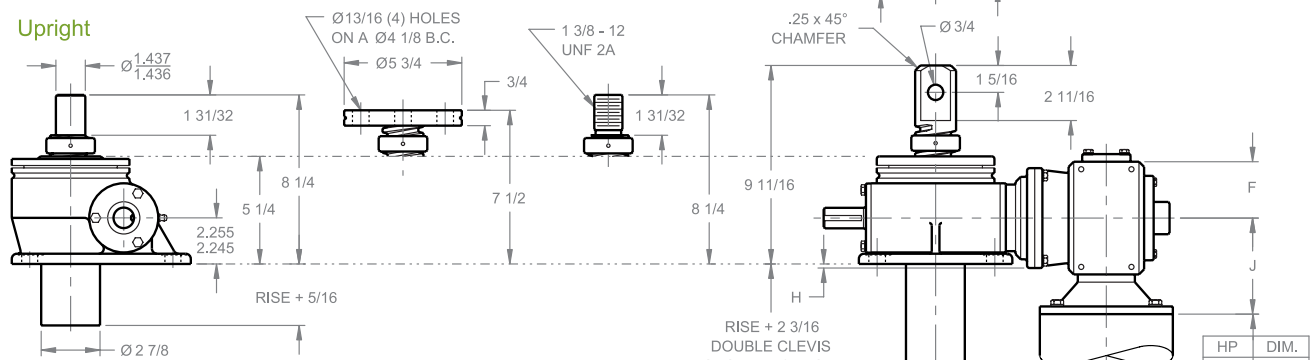

Upright traveling nut

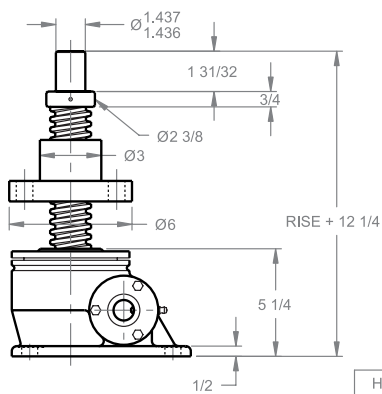

Inverted traveling nut

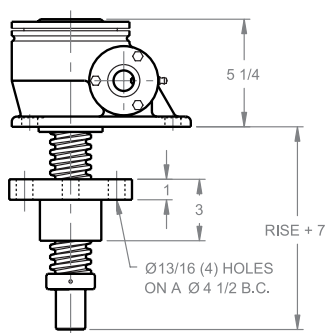

Inverted

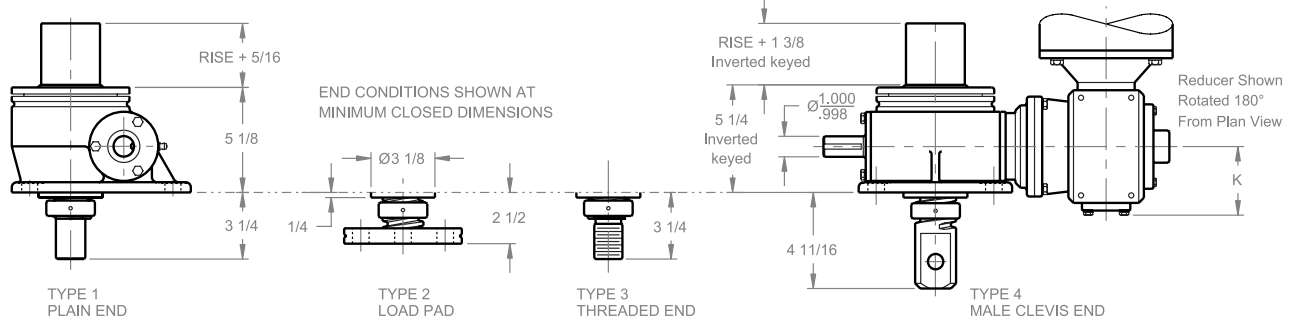

NOTE: FOR LIFTING CAPACITIES SEE PAGE 49

Note: Drawings are artist's conception — not for certification; dimensions are subject to change without notice.

REDUCER DIMENSIONS			
HP	1, 1 1/2, 2	3, 5	
A	8 11/32	8 29/32	
B	11 21/32	13 17/32	
C	1 3/4	2 5/8	
D	3 3/8	4 7/16	
E	8 7/16	11 11/16	
F	2 3/4	3 7/8	
G	4 15/32	4 15/32	
H	3/16	1 5/8	
J	4 11/16	5 3/4	
K	3 11/32	4 5/16	

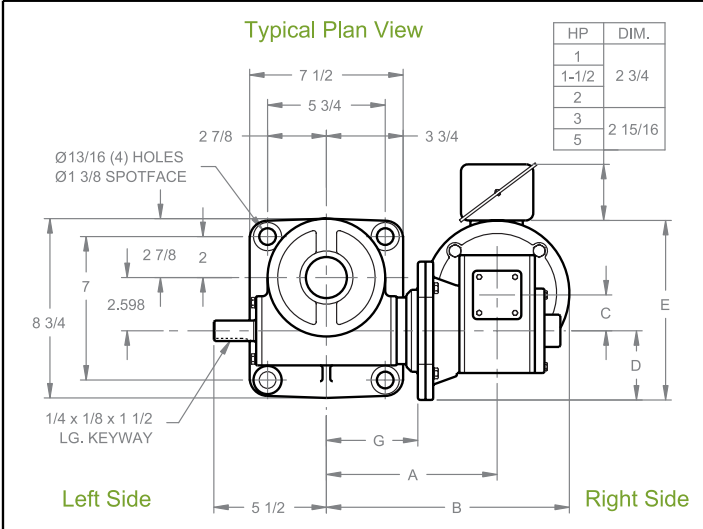

HP	DIM.
1	10 1/4
1-1/2	11 1/4
2	17 3/8
3	18 3/4

HP	DIM.
1	Ø7 3/16
1-1/2	Ø9 1/16
2	
3	
5	

HP	DIM.
1	2 3/4
1-1/2	2 3/4
2	
3	2 15/16
5	

MACHINE SCREW ComDRIVES®

15 TON - 2 1/4" SCREW

CD 815 / DCD 815
CD 2415 / DCD 2415

Upright

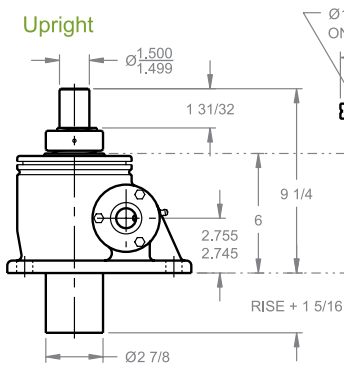

Upright traveling nut

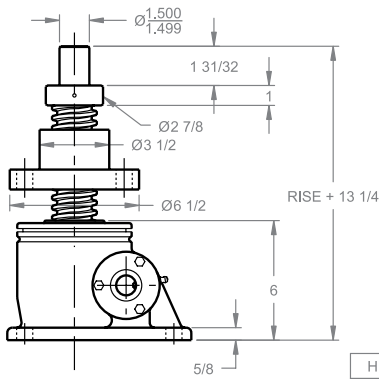

Inverted traveling nut

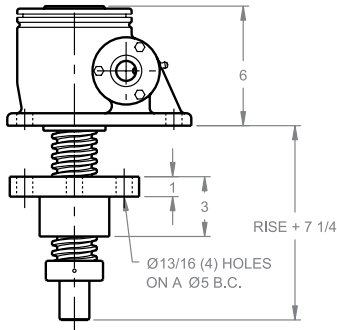

Inverted

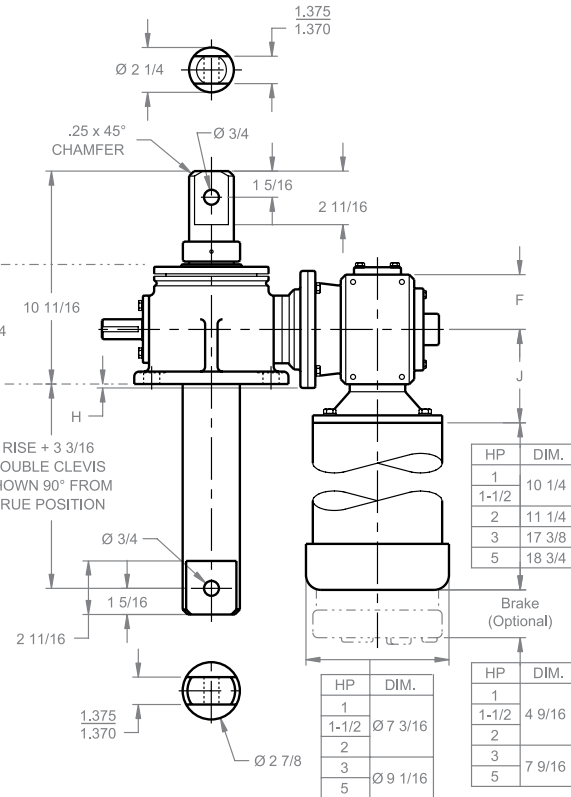
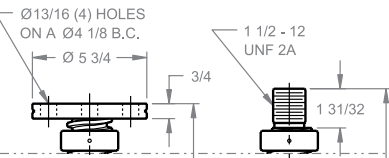
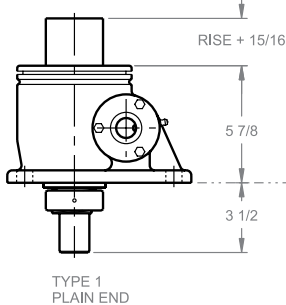

REDUCER DIMENSIONS

HP	1, 1 1/2, 2	3, 5
A	8 11/32	8 29/32
B	11 21/32	13 17/32
C	1 3/4	2 5/8
D	3 3/8	4 7/16
E	8 7/16	11 11/16
F	2 3/4	3 7/8
G	4 15/32	4 15/32
H	3/16	1 5/8
J	4 11/16	5 3/4
K	3 11/32	4 5/16

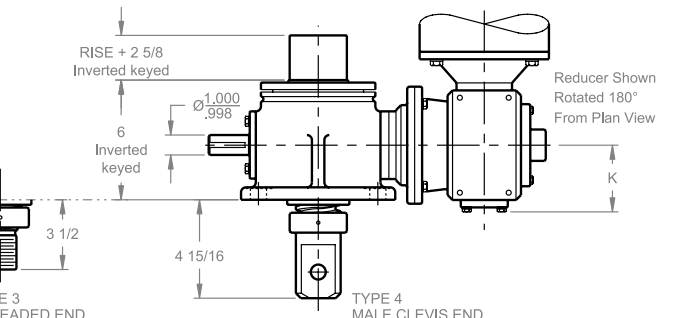
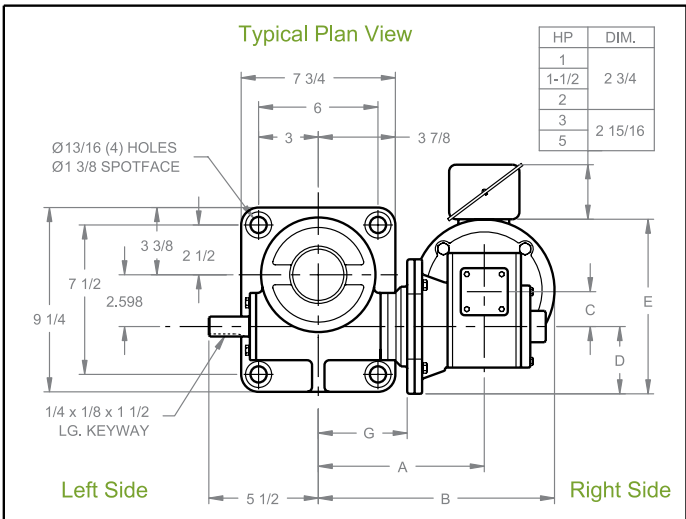

NOTE: FOR LIFTING CAPACITIES SEE PAGE 49

Note: Drawings are artist's conception — not for certification; dimensions are subject to change without notice.

MACHINE SCREW ComDRIVES®

20 TON - 2 1/2" SCREW

CD 820 / DCD 820
CD 2420 / DCD 2420

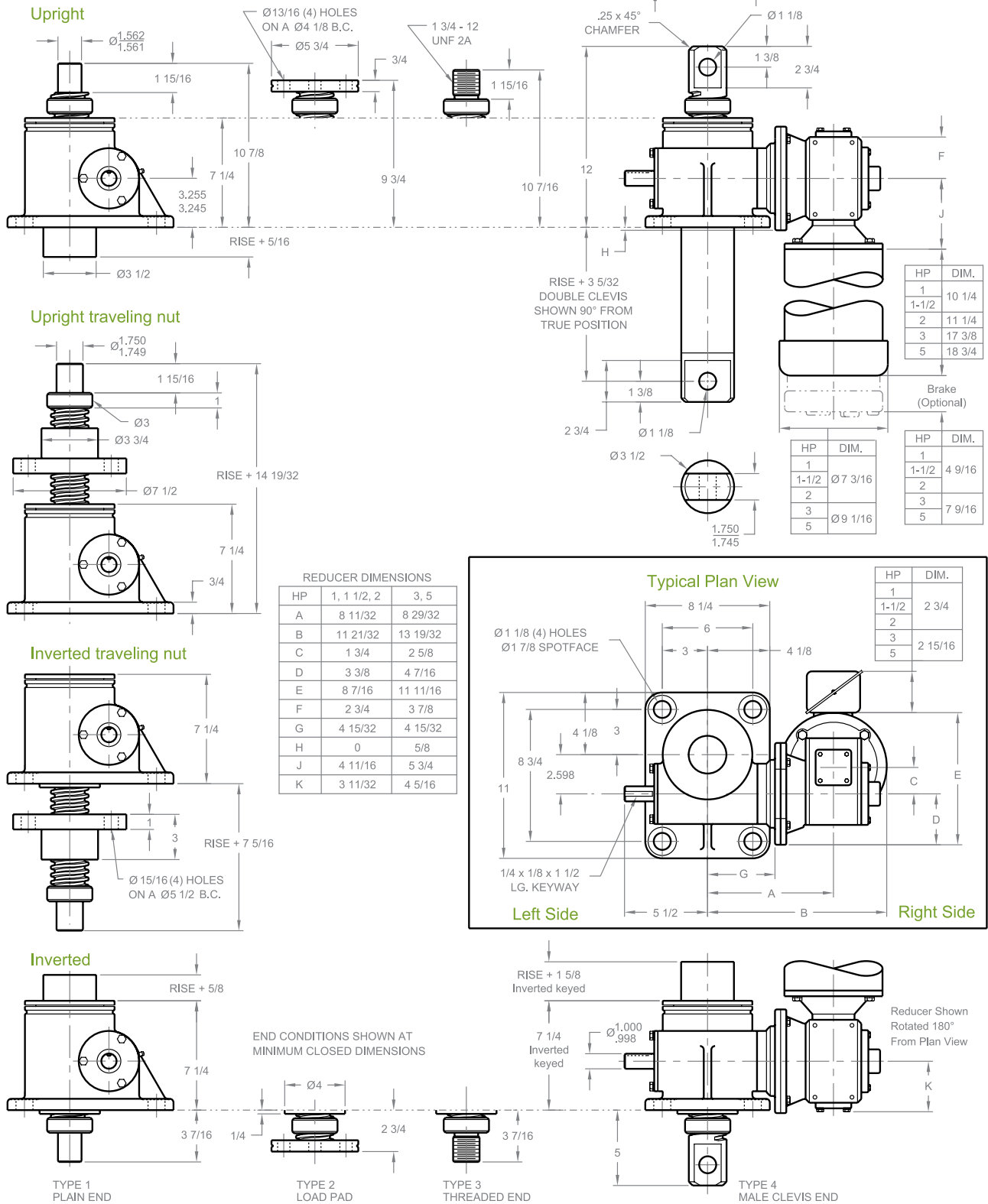

Note: Drawings are artist's conception — not for certification; dimensions are subject to change without notice.

MACHINE SCREW ComDRIVES®

30 TON - 3 1/2" SCREW

CD 1130 / DCD 1130
CD 3230 / DCD 3230

Upright

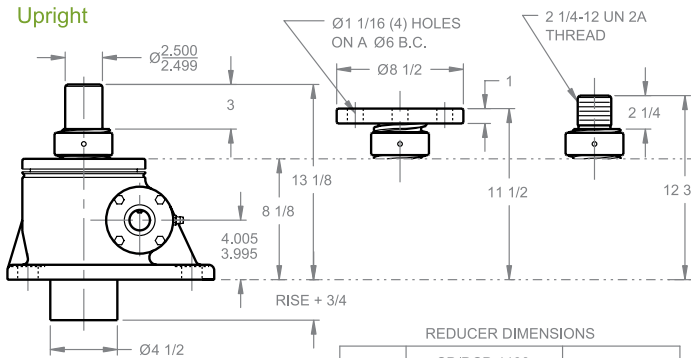

Upright traveling nut

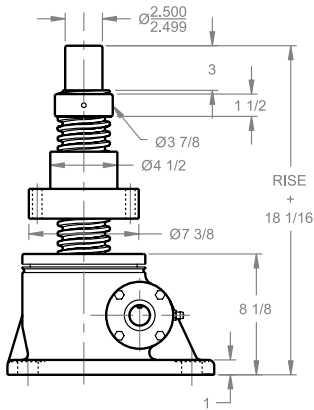

Inverted traveling nut

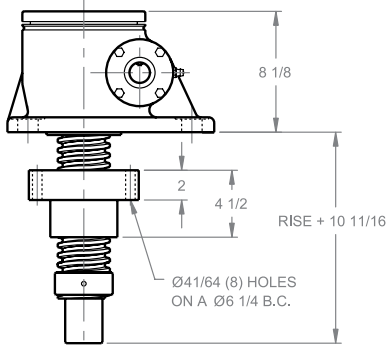

Inverted

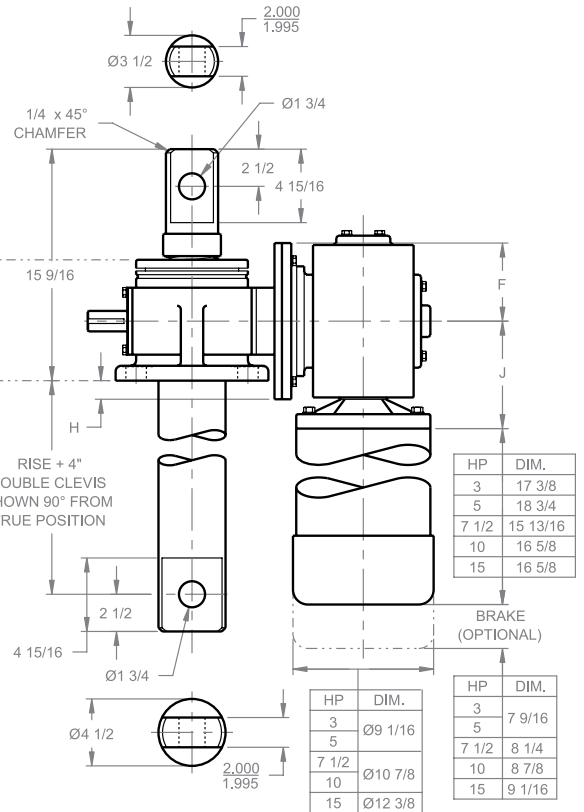
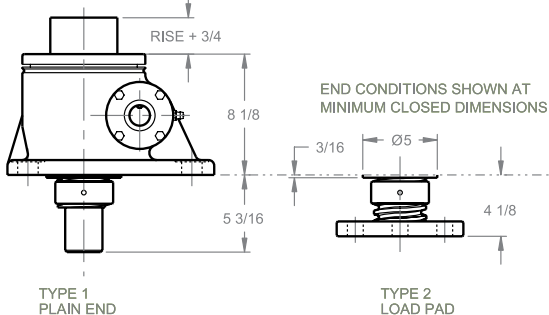

MODEL	CD/DCD 1130				CD/DCD 3230			
	5:1	10:1	5:1	10:1	5:1	10:1	5:1	10:1
RATIO	5:1	10:1	5:1	10:1	5:1	10:1	5:1	10:1
HP	3	5	5	7 1/2	7 1/2	10	15	15
A	9 17/32	9 31/32	11 19/32	11 19/32	11 19/32	11 19/32	11 19/32	11 19/32
B	13 1/32	13 29/32	16 3/32	16 3/32	16 3/32	16 3/32	16 3/32	16 3/32
C	2 5/8	3 1/4	4 1/4	4 1/4	4 1/4	4 1/4	4 1/4	4 1/4
D	4 7/16	5 1/2	6 1/2	6 1/2	6 1/2	6 1/2	6 1/2	6 1/2
E	11 9/16	12 3/4	15 1/4	15 1/4	15 1/4	15 1/4	15 1/4	15 1/4
F	3 9/16	4 1/2	5 1/4	5 1/4	5 1/4	5 1/4	5 1/4	5 1/4
G	5 1/2	5 1/2	5 1/2	5 1/2	5 1/2	5 1/2	5 1/2	5 1/2
H	0	1/2	1 1/4	1 1/4	1 1/4	1 1/4	1 1/4	1 1/4
J	4 11/16	6 3/4	7 1/4	7 1/4	7 1/4	7 1/4	7 1/4	7 1/4
K	3 11/32	4 5/16	6 1/8	6 1/8	6 1/8	6 1/8	6 1/8	6 1/8

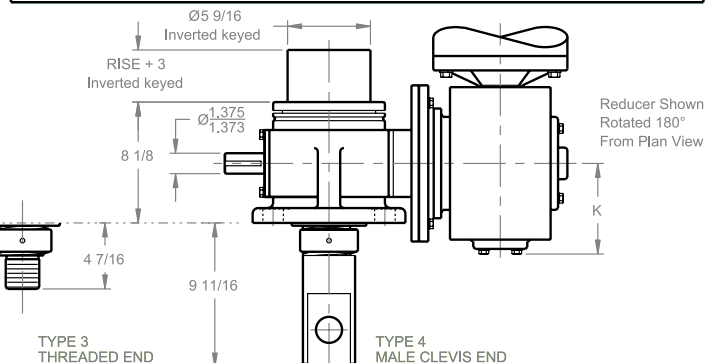
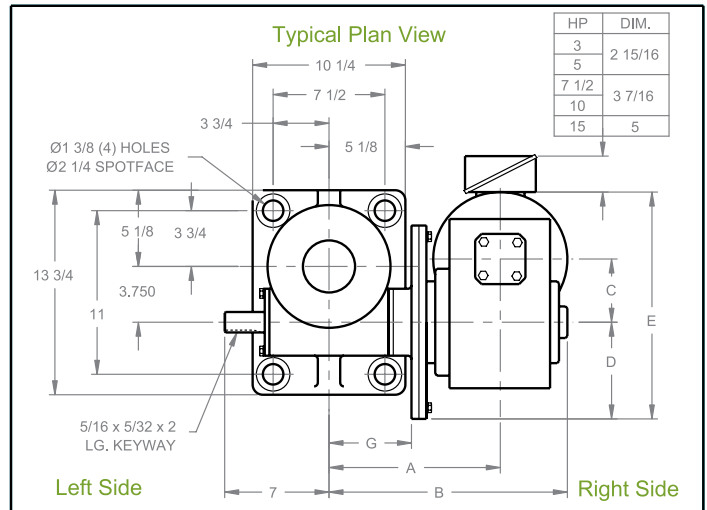

Note: Drawings are artist's conception — not for certification; dimensions are subject to change without notice.