

Joyce stainless steel screw jacks are specifically designed for positioning and lifting applications that are located in wet, corrosive or other harsh environments. In most cases, these jacks can be easily retrofitted into applications where non-stainless steel jacks have already been installed.

They are available in 2-ton through 25-ton capacities with either single lead (SWJ) or double lead (DSWJ) lifting screws. SWJ series jacks are self-locking under full lifting capacity. DSWJ series jacks offer increased travel speeds.

- All exposed surfaces and components feature 316 or 17-4 stainless steel construction and bronze (bushings and traveling nut).
- Nitrile rubber seals protect all internal mechanisms.
- Tapered roller or ball thrust bearings provide rugged reliability.

They are available with one of four standard screw ends or special ends to meet your requirements. Double input shafts are standard. An optional anti-backlash feature (pages 180 and 181) compensates for thread wear, assuring minimum play between lifting screw and wormgear for smooth, precise operation. All jack designs can be fitted with protective boots.

Joyce/Dayton can customize stainless steel jacks to meet your specifications.

**Stainless steel jacks are widely used in many industries including the following:**

- **Food handling**
- **Paper mill**
- **Printing**
- **Defense**
- **Coastal installations**

# STAINLESS STEEL SCREW JACKS

Joyce/Dayton offers  
Stainless Steel Screw Jacks  
in several designs including:

- Translating
- Keyed for non-rotation
- Keyed for traveling nut (KFTN)
- Double clevis

A guide for ordering is on pages 60 and 61.

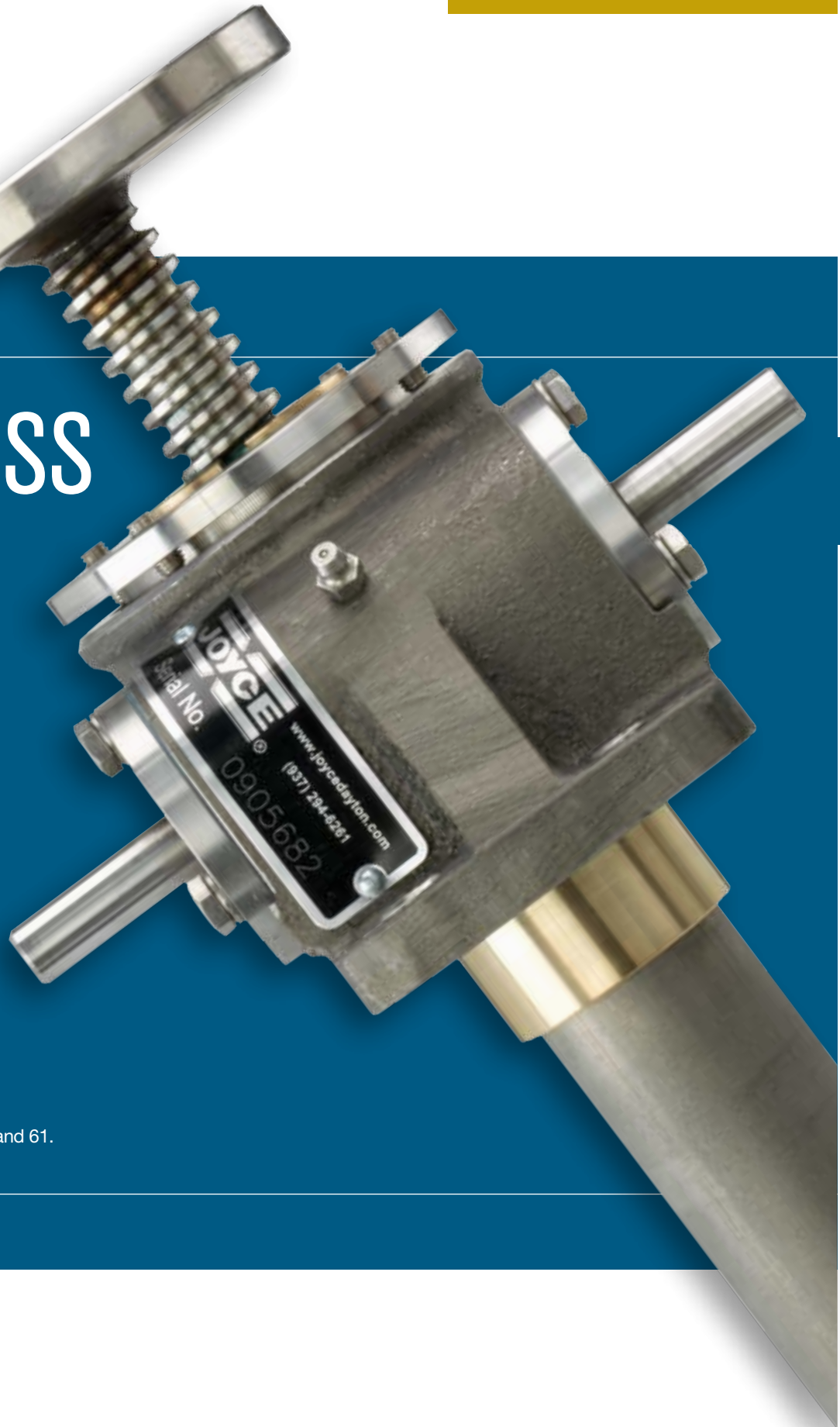

# STAINLESS STEEL JACKS ORDERING INFORMATION

**Instructions:** Select a model number from this chart.

2-Ton	2-Ton Reverse Base	5-Ton	10-Ton	15-Ton	20-Ton	25-Ton
SWJ62 SWJ122 SWJ242	RSWJ62 RSWJ122 RSWJ242	SWJ65 SWJ125 SWJ245	SWJ810 SWJ2410	SWJ815 SWJ2415	SWJ820 SWJ2420	SWJ1125 SWJ3225
DSWJ62* DSWJ122* DSWJ242*	DRSWJ62* DRSWJ122* DRSWJ242*	DSWJ65* DSWJ125* DSWJ245*	DSWJ810* DSWJ2410*	DSWJ815* DSWJ2415*	DSWJ820* DSWJ2420*	DSWJ1125* DSWJ3225*

**Important Note:** \*Not self-locking, may lower under load. Brake motors or external locking systems are recommended.

**D:** Double Lead Screw.

**R:** Reverse Base Jack (only available on 2-ton jacks).

(For 25:1 ratio, contact Joyce/Dayton.)

## Sample Part Number: RSWJ62U2S-6.00-STDX-STDX-B

**Jack Configuration**



U=Upright    I=Inverted

**End Conditions**

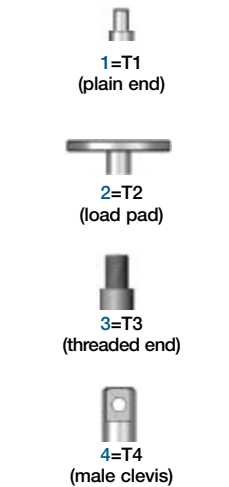

1=T1 (plain end)  
2=T2 (load pad)  
3=T3 (threaded end)  
4=T4 (male clevis)

**Left Side Shaft Code**  
(see below)



XXXX=Remove  
STDX=Standard

For optional shaft codes, see page 61.

**Right Side Shaft Code**  
(see below)



XXXX=Remove  
STDX=Standard

For optional shaft codes, see page 61.

**Additional Options**

X=Standard Jack, no additional options

S=Additional Specification Required (comment as necessary)

Anti-Backlash p. 180  
A=Split Nut  
A90=A90 Design  
A95=A95 Design

Protective Boots pp. 170-172  
B=Protective Boot  
D=Dual Protective Boot

Finishes p. 179  
F2=Epoxy Paint  
F3=Outdoor Paint Process

Motor Options  
M1=Less Motor  
M2=Brake Motor  
M3=Single Phase Motor (120VAC)  
M4=50Hz Motor

Grease/Seals  
H1=High Temperature Operation  
H2=Food Grade

Screw Stops  
ST0=Extending  
ST1=Retracting  
ST2=Both

• Specify as many options as needed

**Stainless Steel Screw Jack Rise**

Rise is travel expressed in inches and not the actual screw length.

**Jack Designs**



S=Translating    K=Keyed for Non Rotation    N=Traveling Nut    D=Double Clevis\*    R=KFTN Trunnion\*  
T=Trunnion\*

\*Contact Joyce/Dayton with your requirements.

# STAINLESS STEEL JACKS SHAFT CODES

**Instructions:** Select the appropriate shaft codes for both right and left hand shafts. One shaft code must be specified for each side of the jack.

**Screw Stops (p. 10) and Boots (pp. 170-172)**

Stainless steel screw stops are optional on stainless steel jacks. When specified, the closed height of the jack and the protection tube length may be increased.

When boots are added to stainless steel jacks, the closed height of the jack may be increased.

**Mechanical Counters (p.177)**

CNT0=0.001" Increments

Note: Contact Joyce/Dayton for availability and options.



**Hand Wheels (p. 177)**

HW04=4" dia  
 HW06=6" dia  
 HW08=8" dia  
 HW10=10" dia  
 HW12=12" dia

Recommended for self-locking jacks only.



**Geared Potentiometers (p. 176)**

POTA=0-10V (IP65)  
 POTB=4-20MA (IP65)  
 POTC=0-10V w/2 switches\*  
 POTD=4-20MA w/2 switches\*

\*Optional IP65 rating available.



**Encoders and Electronic Limit Switches**

ENCX=Encoder (p. 178)  
 ELS2=2 Position Electronic Switch (p. 174)  
 ELS4=4 Position Electronic Switch (p. 174)  
 ELS6=6 Position Electronic Switch (p. 174)



**Motors for Systems and Direct Drives (p. 185)**

- All standard motors are 3-phase, 208-230/460 VAC or 230/460 VAC. Other motor options are available. Specify the appropriate motor size from the chart on the right.
- Refer to the "Additional Options" chart on the preceding page as needed.
- Brake motors (M2) are recommended for jacks that are not self locking and jacks with double lead screws.
- If the motor frequency will be varied to provide a "soft" start, an inverter duty motor may be required.

**Motors**

Size	Code
1/4 HP	K
1/3 HP	A
1/2 HP	B
3/4 HP	C
1 HP	D
1-1/2 HP	E
2 HP	F
3 HP	L
5 HP	G
7-1/2 HP	H
10 HP	I
15 HP	J

**Motor Mounts (p. 185)**

Ordering Example: **MMA A**



MMA=56C  
 MMB=140TC  
 MMC=180TC  
 MMD=210TC

Standard motor adapters are aluminum.

Motor code from chart at left

**Mechanical Limit Switches (pp. 174-175)**

**Ordering Example: LA13**

Models		Number of DPDT Switches (see p. 175)	Available Positions							
Model	Code		1	2*	3	4	5	6*	7	8
LS7-402	LI	NOTE: Will always be 0 for LS7 models								
LS8-402	LA									
LS8-404	LB									
LS9-502	LC									
LS9-503	LD									
LS9-504	LE									
LS9-505	LF									
LS9-506	LG									
LS9-507	LH									

• 2, 5, 10, 15, and 20 ton stainless steel jacks are available with positions #1, #3, and #5.  
 • 25 ton stainless steel jacks are available with positions # 1, #4, #7, and #8.  
 \*These positions are not standard. Contact Joyce/Dayton with your requirements.  
 Note: Limit switch housings are not stainless steel. Choose Steel It epoxy paint option instead.

# STAINLESS STEEL JACKS COLUMN LOADING

Stainless Steel Screw Jack Column Loading Chart

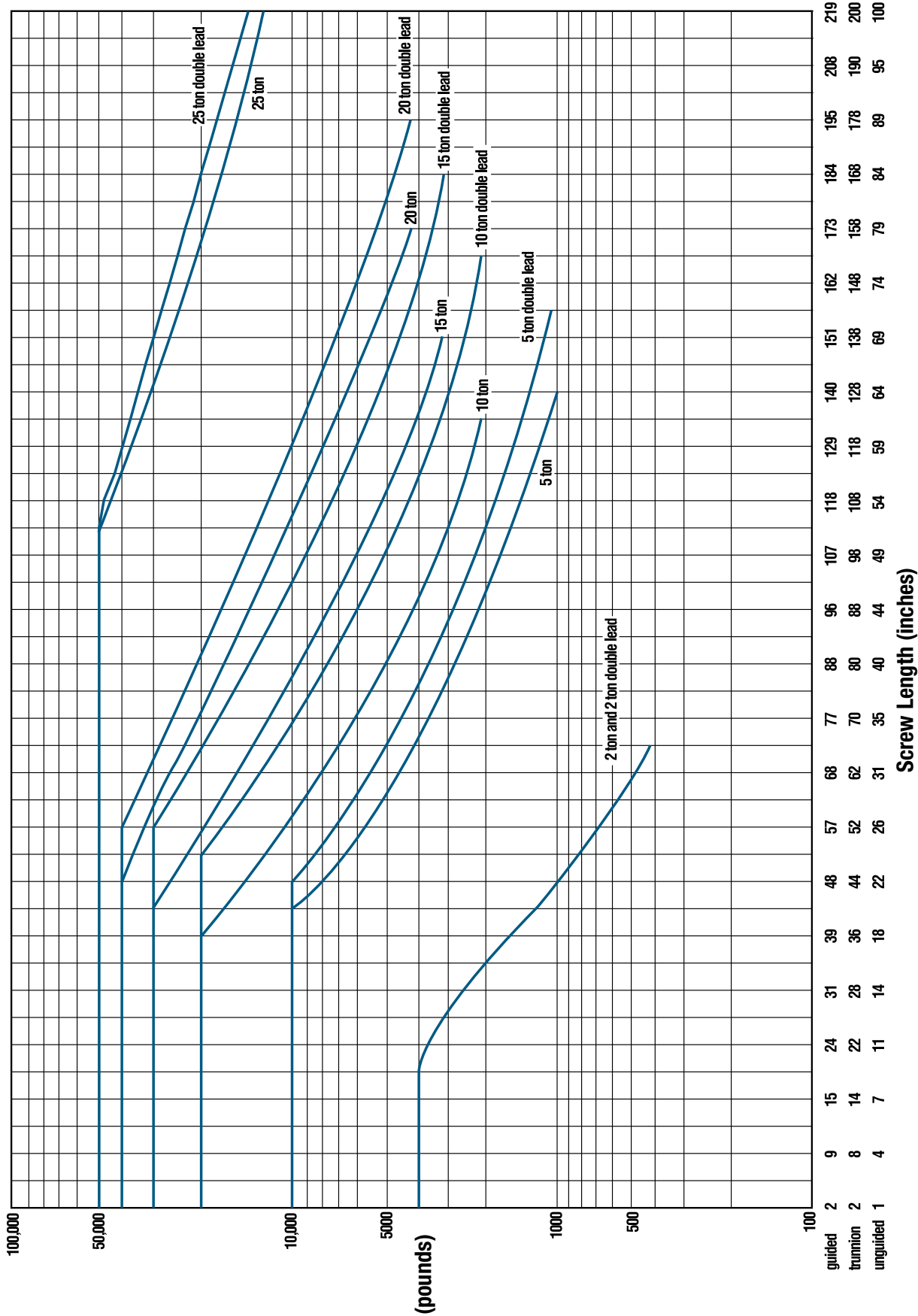

This chart includes a 2:1 Factor-of-Safety based on the Euler-Johnson equation for column loading (Oberg, Erik et al: Machinery's Handbook, 24th Edition. c. 1992 Industrial Press Inc.) The horizontal portion of each line represents the jack's maximum dynamic capacity. Under static conditions, these lines can be exceeded. Please contact factory for assistance.

# STAINLESS STEEL JACKS SPECIFICATIONS

Model	Capacity	Screw Diameter (inches)	Thread Pitch/Lead	Worm Gear Ratio	Worm Shaft Turns for 1" Travel	Tare Torque (Inch Lbs.)	Starting Torque (Inch Lbs.)	Operating Torque (Inch Lbs.)	Efficiency Rating % Approx	Screw Torque (Inch Lbs.)	Basic Jack Weight (Lbs.)	Jack Weight per Inch Travel (Lbs.)
(R)SWJ62	2 ton	1	.250 pitch ACME 2C	6:1	24	6	.041W*	.028W* @ 500 RPM	24.2	.098W*	15	0.3
(R)SWJ122				12:1	48		.025W*	.015W* @ 500 RPM	22.0			
(R)SWJ242				24:1	96		.018W*	.009W* @ 500 RPM	18.3			
D(R)SWJ62			6:1	12	.057W*		.039W* @ 500 RPM	33.7				
D(R)SWJ122			12:1	24	.035W*		.022W* @ 500 RPM	30.5				
D(R)SWJ242			24:1	48	.025W*		.013W* @ 500 RPM	25.4				
SWJ65	5 ton	1 1/2	.375 pitch STUB ACME	6:1	16	15	.065W*	.044W* @ 300 RPM	23.0	.151W*	32	0.7
SWJ125				12:1	32		.041W*	.025W* @ 300 RPM	20.6			
SWJ245				24:1	64		.029W*	.015W* @ 300 RPM	16.7			
DSWJ65			6:1	12	.072W*		.050W* @ 300 RPM	26.8				
DSWJ125			12:1	24	.045W*		.028W* @ 300 RPM	23.9				
DSWJ245			24:1	48	.033W*		.017W* @ 300 RPM	19.6				
SWJ810	10 ton	2	.500 pitch ACME 2C	8:1	16	30	.061W*	.043W* @ 200 RPM	23.1	.195W*	43	1.3
SWJ2410				24:1	48		.030W*	.018W* @ 200 RPM	18.8			
DSWJ810			.333 pitch .667 lead ACME 2C	8:1	12		.070W*	.062W* @ 200 RPM	31.9	.228W*		
DSWJ2410				24:1	36		.035W*	.026W* @ 200 RPM	25.9			
SWJ815	15 ton	2 1/4	.500 pitch ACME 2C	8:1	16	45	.069W*	.047W* @ 200 RPM	21.1	.210W*	59	1.4
SWJ2415				24:1	48		.036W*	.020W* @ 200 RPM	16.6			
DSWJ815			.333 pitch .667 lead ACME 2C	8:1	12		.079W*	.058W* @ 200 RPM	34.4	.244W*		
DSWJ2415				24:1	36		.041W*	.025W* @ 200 RPM	27			
SWJ820	20 ton	2 1/2	.500 pitch ACME 2C	8:1	16	60	.075W*	.051W* @ 200 RPM	19.6	.227W*	77	1.9
SWJ2420				24:1	48		.039W*	.022W* @ 200 RPM	15.4			
DSWJ820			.375 pitch .750 lead ACME 2C	8:1	10.67		.088W*	.061W* @ 200 RPM	24.5	.272W*		
DSWJ2420				24:1	32		.046W*	.026W* @ 200 RPM	19.3			
SWJ1125	25 ton	3 3/8	.666 pitch STUB ACME	11:1	16	75	.088W*	.055W* @ 200 RPM	18.3	.313W*	164	3.1
SWJ3225				32:1	48		.053W*	.025W* @ 200 RPM	13.5			
DSWJ1125			.5625 pitch 1.125 lead ACME 2C	11:1	9.5		.106W*	.067W* @ 200 RPM	25.1	.384W*		
DSWJ3225				32:1	28.5		.063W*	.030W* @ 200 RPM	18.6			

**Important Note:** Series DSWJ models may lower under load. Brake motors or external locking systems are recommended.

(R): Reverse Base Jack.

\*W: Load in pounds.

**Tare Torque:** Initial torque to overcome seal and normal assembly drag. This value must be added to starting torque or operating torque values.

**Starting Torque:** Torque value required to start moving a given load (dissipates to operating torque values once the load begins moving).

**Operating Torque:** Torque required to continuously raise a given load at the input RPM listed.

**Note:** If your actual input RPM is 20% higher or lower than the listed RPM, please refer to our JAX® program to determine actual torque values at your RPM.

**Screw Torque:** Torque required to resist screw rotation (Translating Design Jacks) and traveling nut rotation (Keyed for Traveling Nut Design Jacks).

**Lead:** The distance traveled axially in one rotation of the lifting screw.

**Pitch:** The distance from a point on a screw thread to a corresponding point on the next thread, measured axially.

# STAINLESS STEEL JACKS

## 2 TON - 1" SCREW

SWJ 62 / DSWJ 62  
 SWJ 122 / DSWJ 122  
 SWJ 242 / DSWJ 242

### Upright

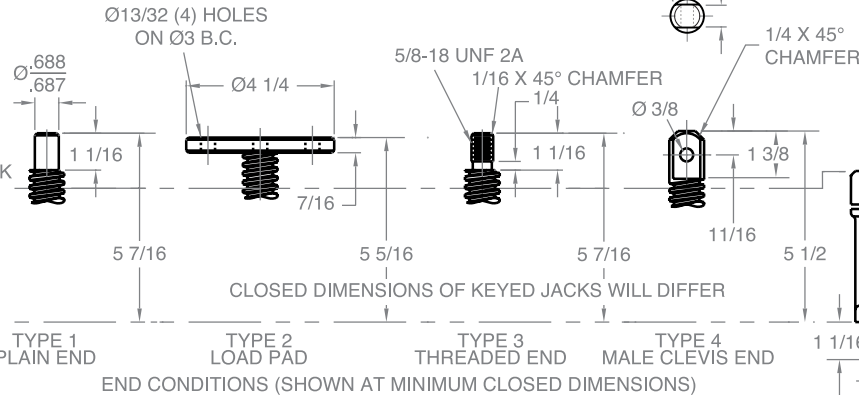
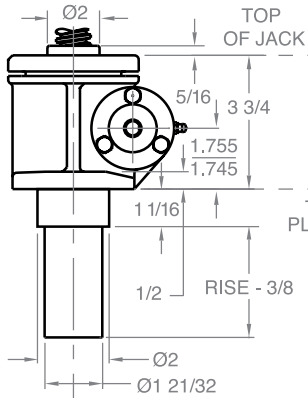

### Upright keyed

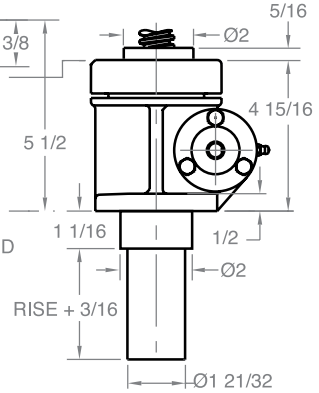

### Typical Plan View

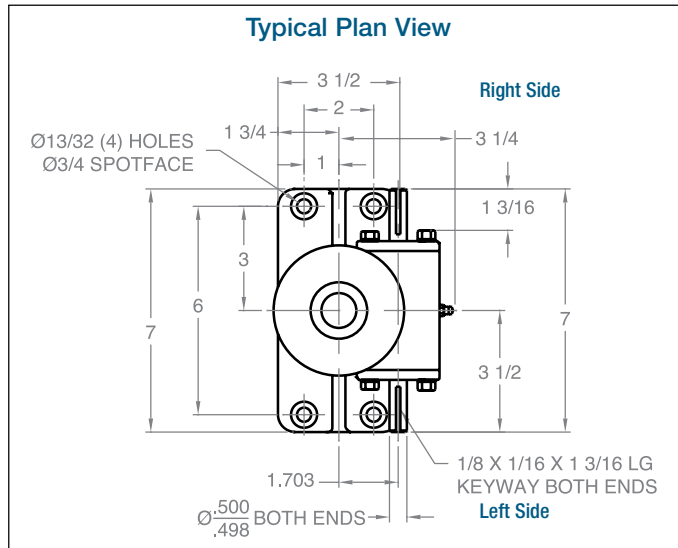

### Upright traveling nut

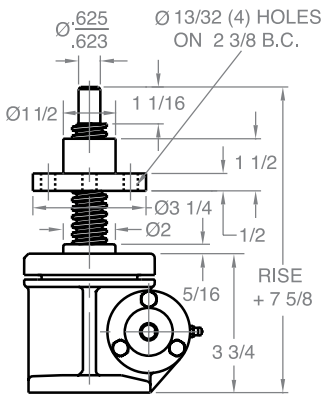

### Inverted traveling nut

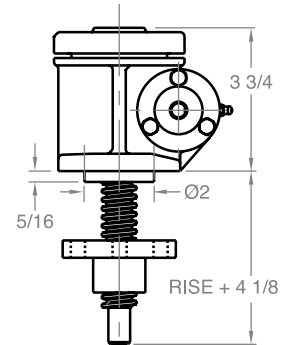

### Double Clevis

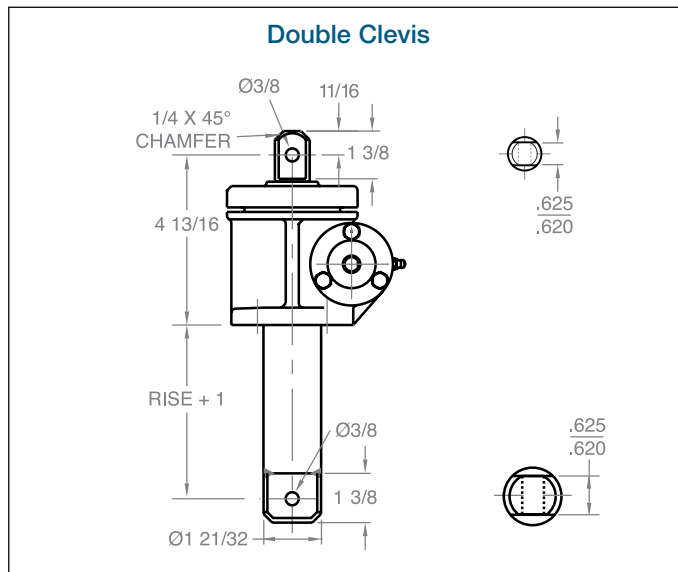

### Inverted

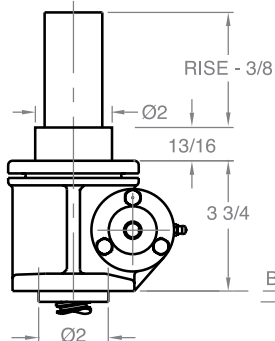

### Inverted keyed

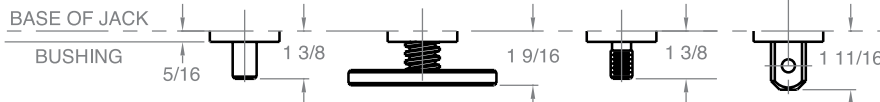
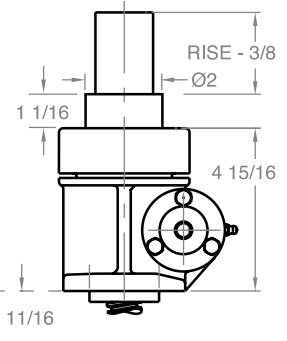

Note: Drawings are artist's conception — not for certification; dimensions are subject to change without notice.



# STAINLESS STEEL JACKS

5 TON - 1 1/2" SCREW

SWJ 65 / DSWJ 65  
 SWJ 125 / DSWJ 125  
 SWJ 245 / DSWJ 245

## Upright

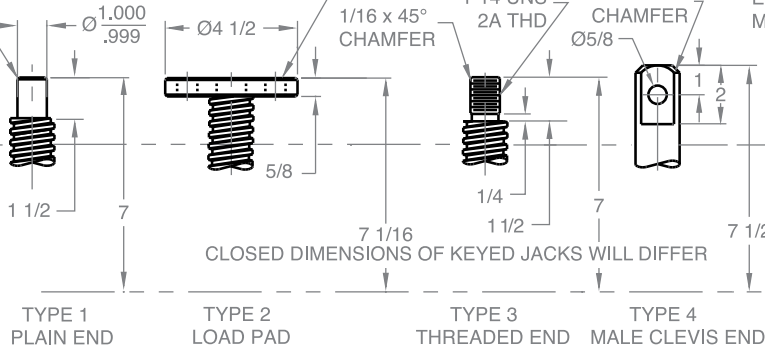
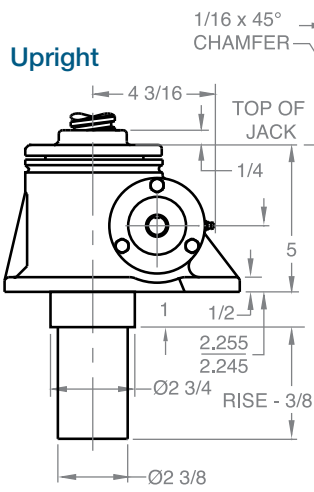

END CONDITIONS (SHOWN AT MINIMUM CLOSED POSITION)

## Upright keyed

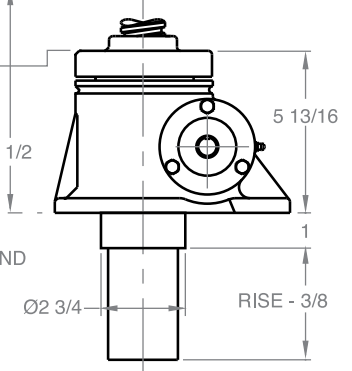

## Upright traveling nut

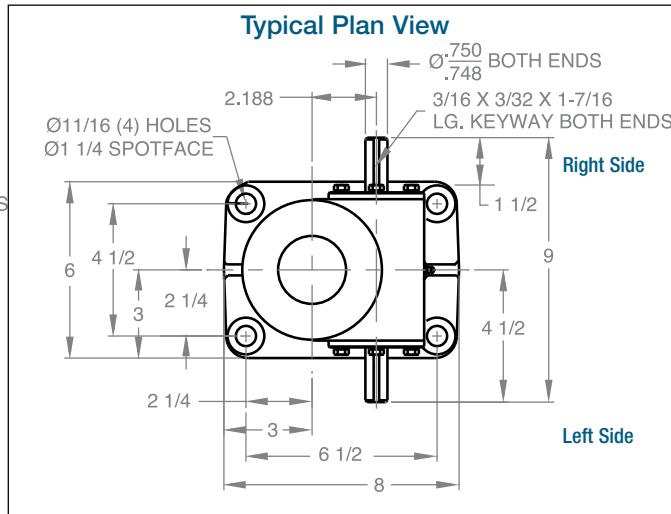
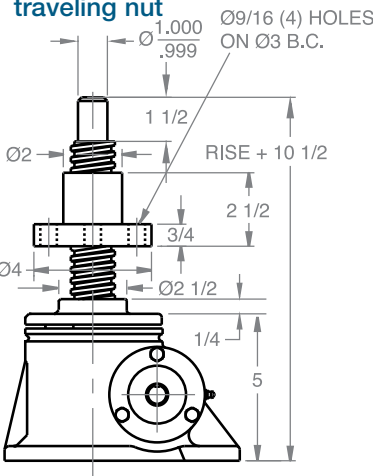

## Inverted traveling nut

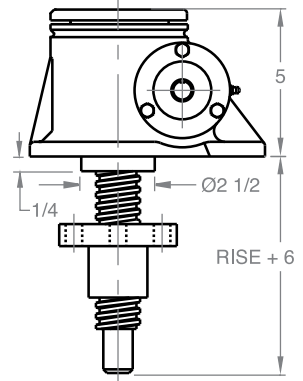

## Inverted

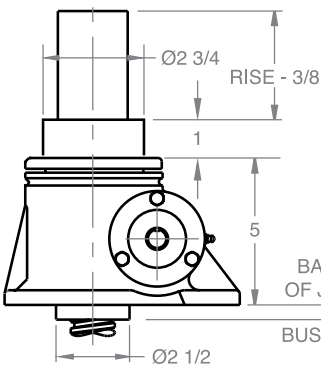

## Double Clevis

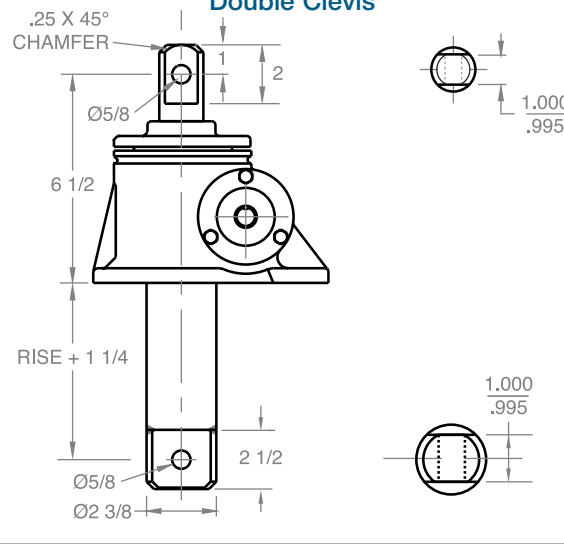

## Inverted keyed

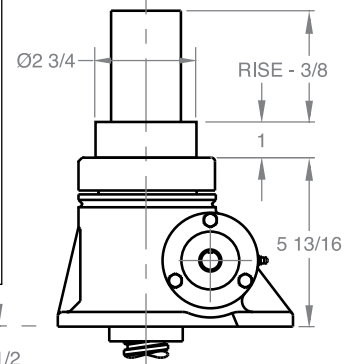

Note: Drawings are artist's conception — not for certification; dimensions are subject to change without notice.

# STAINLESS STEEL JACKS

## 10 TON - 2" SCREW

SWJ 810 / SWJ 2410  
DSWJ 810 / DSWJ 2410

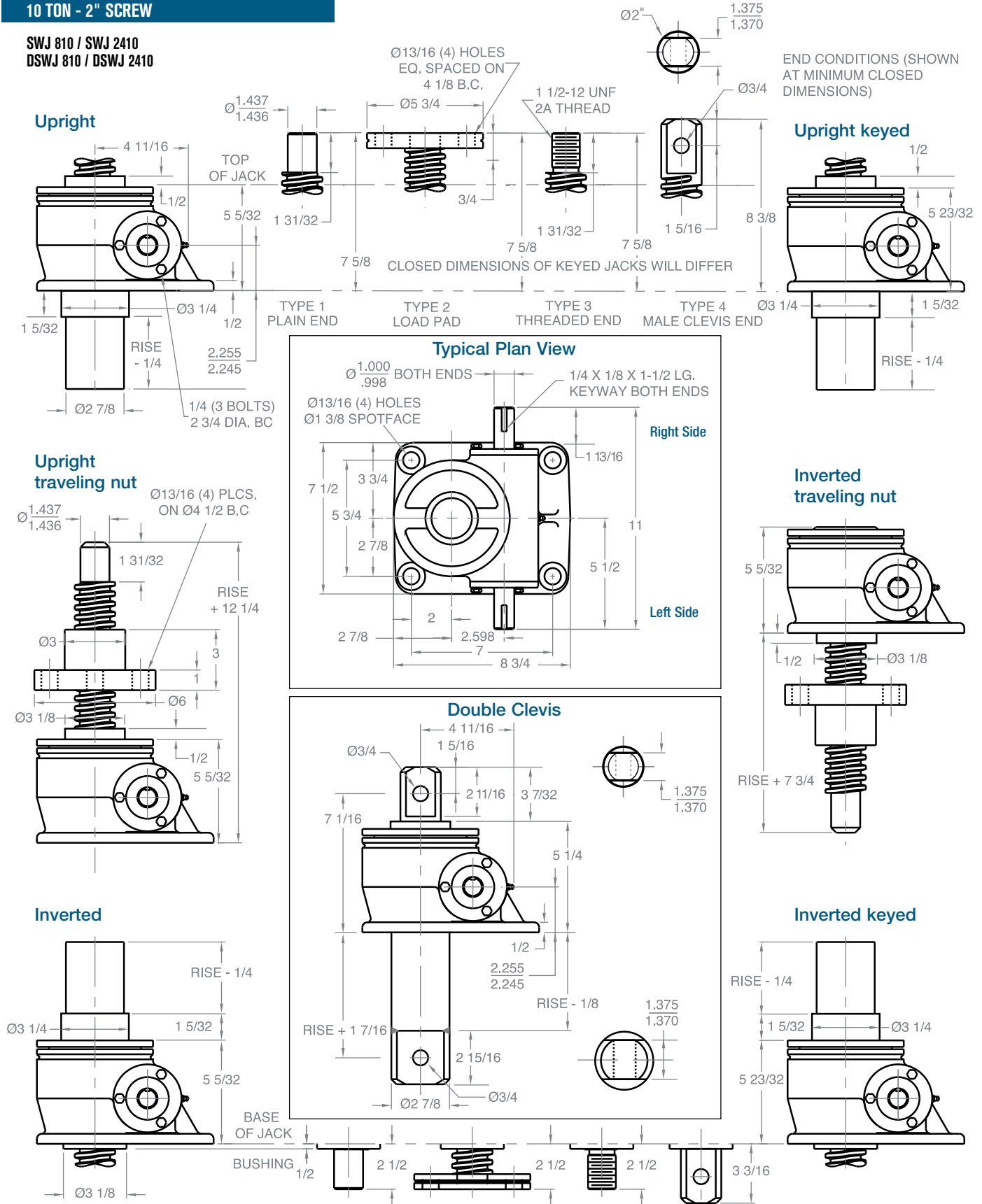

Note: Drawings are artist's conception — not for certification; dimensions are subject to change without notice.



# STAINLESS STEEL JACKS

## 20 TON - 2 1/2" SCREW

SWJ 820 / SWJ 2420  
DSWJ 820 / DSWJ 2420

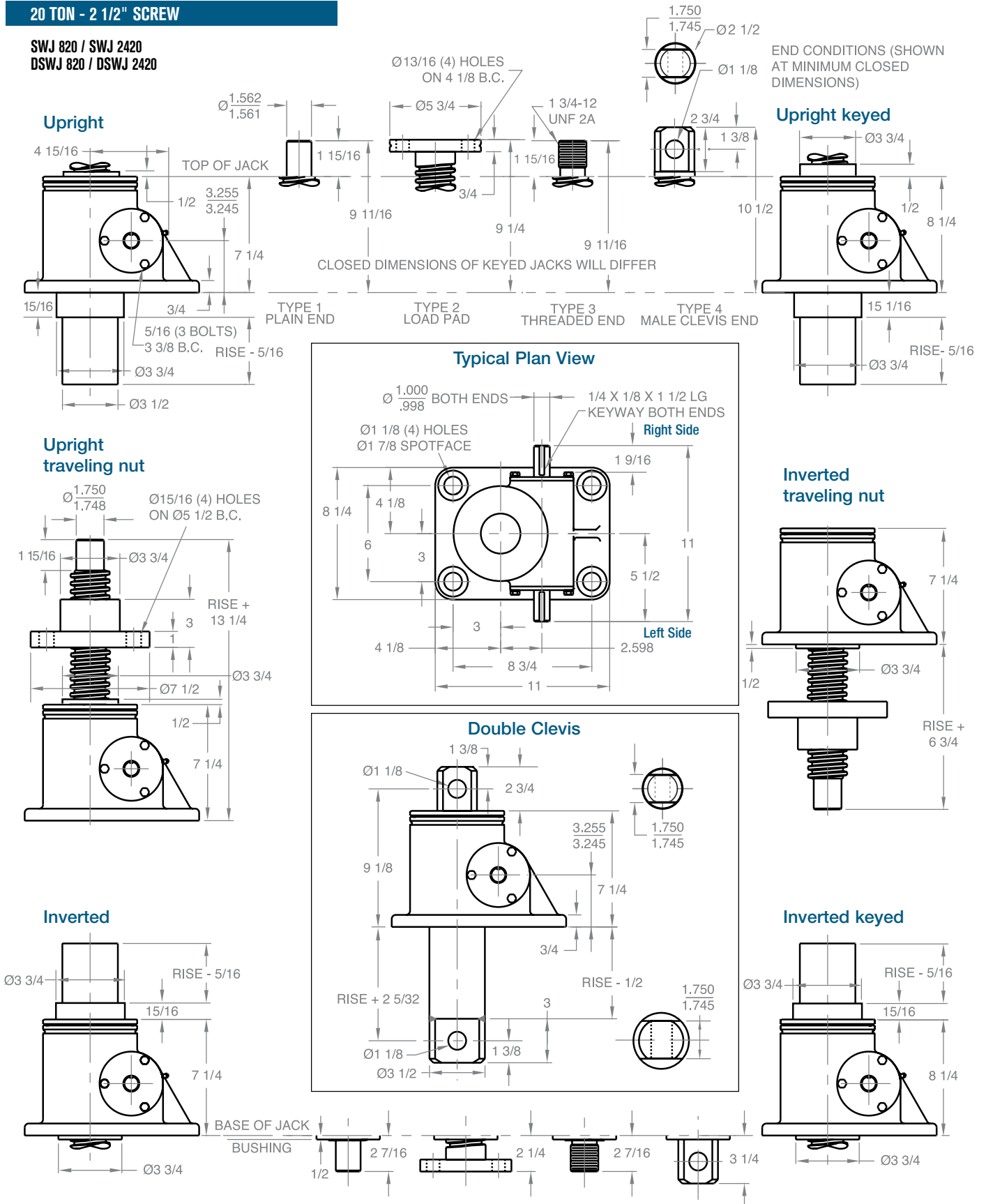

Note: Drawings are artist's conception — not for certification; dimensions are subject to change without notice.

# STAINLESS STEEL JACKS

## 25 TON - 3 3/8" SCREW

SWJ 1125 / SWJ 3225  
DSWJ 1125 / DSWJ 3225

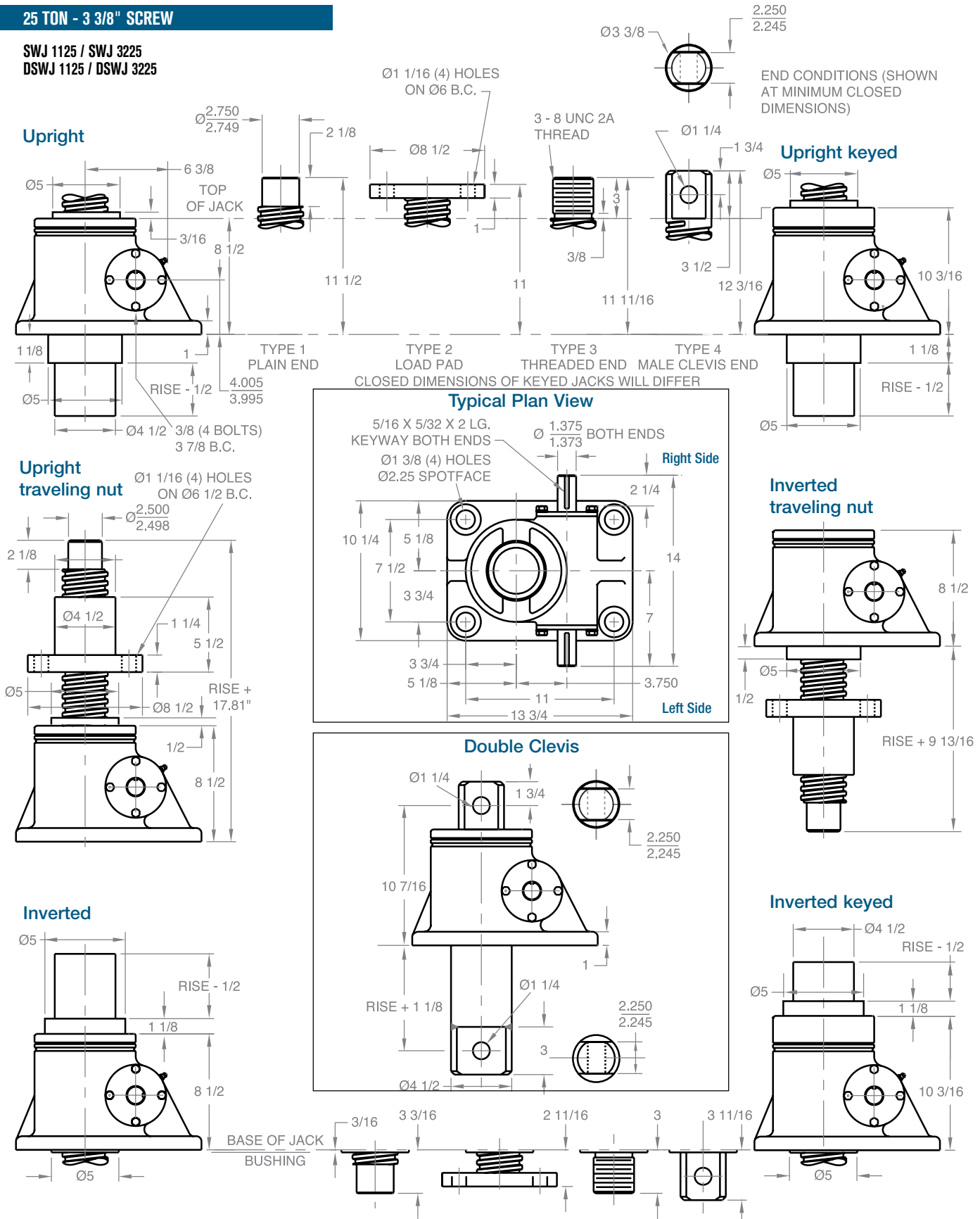

Note: Drawings are artist's conception — not for certification; dimensions are subject to change without notice.