



Joyce/Dayton Corp.

**Operation and Maintenance Manual for
Joyce/Dayton Multipurpose Actuators**



The recommendations in this manual for installation, operation and maintenance must be followed to ensure safe use. All persons responsible for the installation and use of Joyce/Dayton Multipurpose Actuators must be familiar with the contents of this manual.

The customer is responsible for guards and other protective devices and for ensuring that Multipurpose Actuator usage conforms with local and national operating and safety codes appropriate to the class of equipment into which the Multipurpose Actuator is installed.

Table of Contents

Section I – General Information

1-1 Contact Joyce/Dayton.....	3
1-2 Purpose and Scope	3
1-3 Receipt of Product.....	3
1-4 Warranty	3
1-5 Precautions for Use and Installation	3
1-6 Features	4
1-7 Limit Switch Adjustment	4
1-8 Wiring Instructions for Motor and Potentiometer.....	5
1-9 Mounting Guidelines	6

Section II – Multipurpose Actuator Drawings

2-1 MA0513 Drawing and Charts	7
2-2 MA1527 & MA3507 Drawing and Charts	8
2-3 MA2547, MA3527, MA4514, MA7007 Drawing and Charts	9

Section III – Order Information

3-1 Part Number Description	10
3-2 Serial Number Information	10

Section I

General Information

1-1 Contact Joyce/Dayton Corp.

Joyce/Dayton Corp.
P.O. Box 1630
Dayton, OH 45401
(800) 523-5204 (US and Canada)
(937) 294-6261 (937) 297-7173 Fax
Email: sales@joycedayton.com
Website: www.joycedayton.com

1-2 Purpose and Scope

This manual provides installation, operation and maintenance instruction for standard Joyce/Dayton Multipurpose Actuator. For special units not covered, please contact Joyce/Dayton Corp.

1-3 Receipt of Product

All equipment should be immediately inspected upon receipt for any damage and to verify correct product and quantities. Any problems should be reported to Joyce/Dayton Corp. and the freight carrier as soon as possible. Products returned without a *Return Goods Authorization (RGA)* form will not be accepted. Contact Joyce/Dayton to obtain an RGA.

1-4 Warranty

Seller warrants its products to be free from defects in material and workmanship under normal and proper use in accordance with instruction of seller for a period of one year from the date of shipment to buyer. Seller's liability under such warranty or in connection with any other claim relating to the products shall be limited to the repair, or at seller's option, the replacement or refund of the purchase price of any products or parts or components thereof which are returned to seller freight prepaid and which are defective in material or workmanship. Products or parts or components thereof, which are repaired or replaced by seller will be returned to buyer freight collect. This warranty is not intended to cover consumer products, as defined in the Magnuson-Moss Warranty-Federal Trade Commission Improvement Act, 15 U. S. C. Sections 2301-12, which are purchased by buyer for purposes other than resale. If buyer is not intending to resell the products, and if the products are consumer products as defined in the Magnuson-Moss Act, the foregoing warranty, but not the limitation of seller's liability, shall be null and void. EXCEPT AS EXPRESSLY STATED ABOVE, SELLER MAKES NO WARRANTY, EXPRESS OR IMPLIED, WHETHER OF MERCHANTABILITY OR FITNESS FOR ANY PARTICULAR PURPOSE OR USE OR OTHERWISE, ON THE PRODUCTS, OR ON ANY PARTS OR LABOR FURNISHED DURING THE SALE, DELIVERY OR SERVICING OF THE PRODUCTS.

1-5 Precautions of Use and Installation

1. Each Multipurpose Actuator includes limit switches, which are preset to the design limits of the unit. Customers who choose to make limit switch position adjustments must ensure the limits remain within the design limits of the actuator. Note that adjustments to the preset positions need to be made before the actuator is installed. Limit switches on MA0513 are not adjustable.
1. It is necessary that appropriate, qualified personnel perform the installation of Joyce/Dayton products. Ensure that all personnel who will service or operate equipment are familiar with its use and limitations.
2. Joyce/Dayton Multipurpose Actuators are not rated for shock-loading or extreme vibration. It is the responsibility of the user to ensure these conditions are not imposed on the actuator.
3. In the event that service or maintenance is required, the load must be secured or removed before any work can begin.

4. Multipurpose actuators can be mounted and operated in any orientation, but the load must be axial to the actuator. No side load is permitted.
5. Be certain the rating of the actuator meets or exceeds the load.
6. The actuator must be mounted on a rigid structure sufficient to support the maximum possible load. An under-designed structure could lead to premature wear or failure.
7. When fastening the load to an actuator, make sure the actuator is in the retracted position. This positions the load accurately with respect to the lifting screw centerline. Never pull the translating tube to one side to make connection with your structure. Fully extend the actuator to make sure the load is aligned with the translating tube.

1-6 Features

- 12 volt DC motor
- Preset limit switches (Adjustable, except for MA0513, which are not adjustable)
- Self-locking
- Potentiometer
- Clevis-to-Clevis Mounting Style
- 25% duty cycle
- IP65 protection rating
- Operating temperatures -26°C to 65°C (-13°F to 149°F)

1-7 Limit Switch Adjustment

Follow these instructions to adjust the preset travel limits on all units except MA0513 Actuators. Limit switches on MA0513 actuators are not adjustable.

Use caution and make sure you do not come in contact with the inner tube while the motor is running. (Refer to Figure 1 and Figure 2 on the following page.)

1. Using the DC motor input, retract the actuator to its lowest position until the limit cam touches the lower limit switch and the motor stops.
2. Secure the load and remove the actuator from the structure before adjusting the limit switch position.
3. Turn the inner tube until the desired retracted position is reached.
4. Unthread the cord grip nut (strain relief) at the base of the pigtail wire to facilitate the removal of the limit switch cover.
5. Using an Allen wrench remove the five hex head cap screws at the base of the actuator housing, and gently pull the limit switch cover off the housing. It may be necessary to straighten the wires in the pigtail to facilitate separation. This will expose the limit switch assembly.
6. The lower cam is located at the bottom of the cam stack, just above the gear and closest to the surface on which it is mounted. It is used to set the retracted position.
7. Loosen the Phillips head screw at the top of the cam assembly and rotate the lower gear and cam until it depresses the lower limit switch. This operation requires patience since the gear and lower cam are separate components.
8. Tighten the Phillips head screw to ensure that the cam and gear do not move while you prepare to set the upper limit switch.
9. Reassemble any two of the socket head cap screws near the cam assembly to secure the outer tube assembly.
10. Turn the inner tube on the actuator until the desired extended position is reached. This position must be less than or equal to the maximum extended position of the actuator.
11. Loosen the Philips-head screw on the limit switch cam assembly and adjust the position of the upper cam until the cam depresses the extended limit switch. Be careful not to disturb the position of the lower cam and gear.
12. Tighten the Philips head screw and remove the two socket head cap screws that were used to temporarily secure the outer tube assembly.

13. Carefully replace the cover, taking care that the gasket is in place and the wires are tucked inside the cover. Tighten the five socket head cap screws that fasten the cover in place.
14. Once the limit switches are set, the unit can be mounted into the assembly.
15. Check the limit switch positions electrically to be sure they are accurately set. If adjustments are needed, follow the steps outlined above.

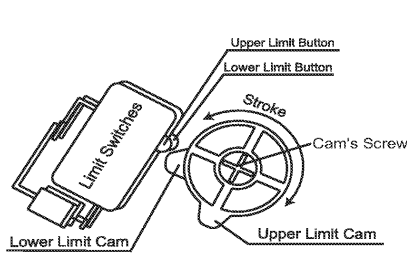

Figure 1 – Limit Switch Schematic

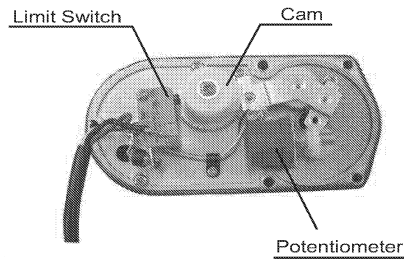

Figure 2 – View of Limit Switch Inside Housing

1-8 Wiring Instructions for Motor and Potentiometer

Motor - MA0513

The actuator will extend when the red wire connects to the positive lead and the black wire connects to the negative lead. It will retract when the black wire connects to the positive lead the red wire connects to the negative lead. See Figure 3 below.

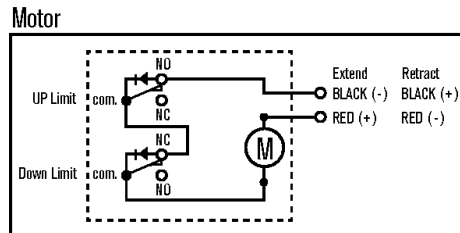

Figure 3 – Motor Schematic MA0513

Motor - MA1527, MA2547, MA3507, MA3527, MA4514, MA7007

The actuator will extend when the red wire connects to the positive lead and the black wire connects to the negative lead. It will retract when the black wire connects to the positive lead the red wire connects to the negative lead. See Figure 4 below.

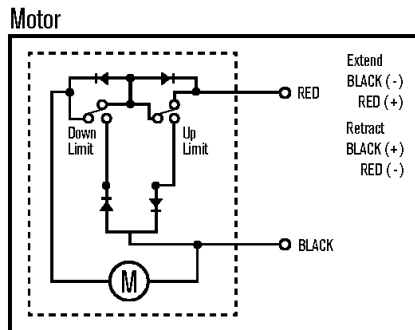

Figure 4 – Motor Schematic MA1527, MA2547, MA3507, MA3527, MA4514, MA7007

Potentiometer - MA0513, MA1527, MA2547, MA3507, MA3527, MA4514, MA7007

The potentiometer has a 0-10 Ohm resistance range. The actual resistance value is a variable that is based on the stroke length. It is measured between the blue and white wires. Values have a +/-0.3 Ohm tolerance. Refer to the Figure 5 and Figure 6 below.

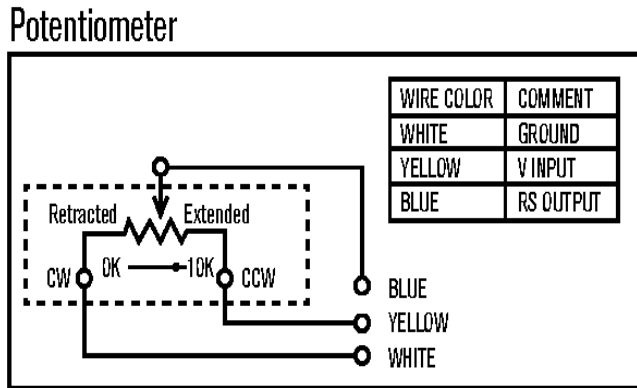

Figure 5 - Potentiometer Schematic

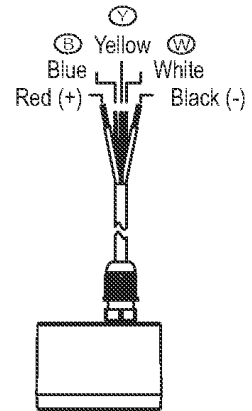

Figure 6 - Wiring Schematic

1-9 Mounting Guidelines

Installation Guidelines

The actuator can be mounted in any orientation but the load should be attached to the actuator and mounted axially so no side load is imposed on the actuator. Figure 7 below shows an axial load in a horizontal plane. Vertical loads can also be mounted axially.

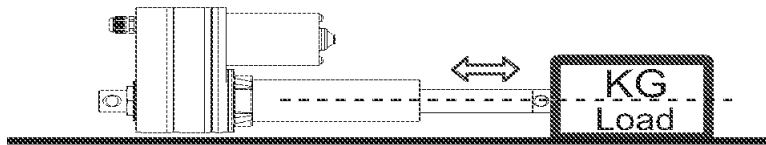

Figure 7 - Example of Axial Load

Figure 8 illustrates a horizontal side load, but it is also possible to impose a side load on a vertically mounted actuator. Side loading is **not** recommended in any orientation.

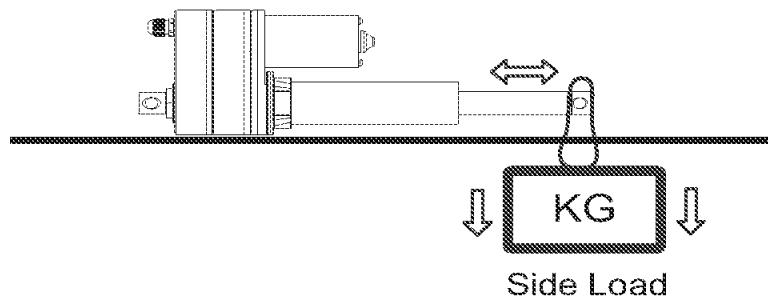
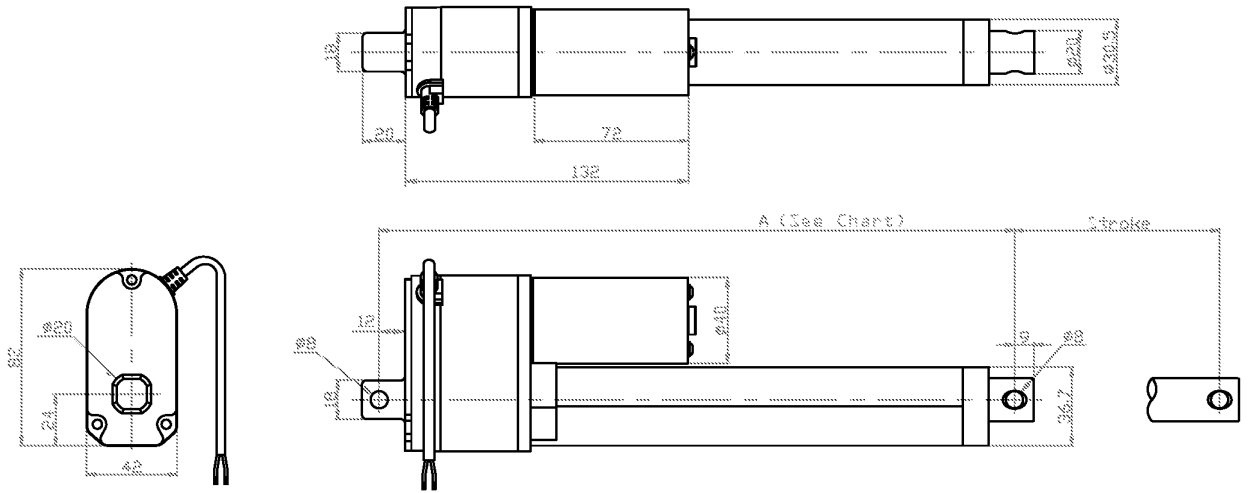

Figure 8 - Example of Side Load- NOT recommended

Section II Multipurpose Actuator Drawings

2-1 MA0513 Drawing and Charts



Drawing dimensions shown in millimeters

Part Number	Capacity N (lb)	Stroke Mm (in)	Travel speed mm/sec (in/min)	Retracted (A) mm (in)
MA0513B1110	500 (112)	100 (3.9)	13 (31)	246 (9.7)
MA0513B1115	500 (112)	150 (5.9)	13 (31)	297 (11.7)
MA0513B1125	500 (112)	250 (9.8)	13 (31)	399 (15.7)
MA0513B1130	500 (112)	300 (11.8)	13 (31)	450 (17.7)

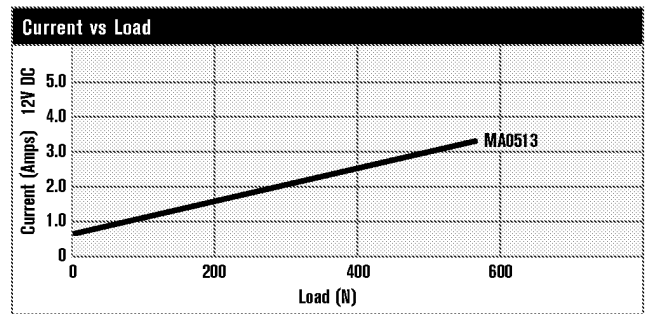
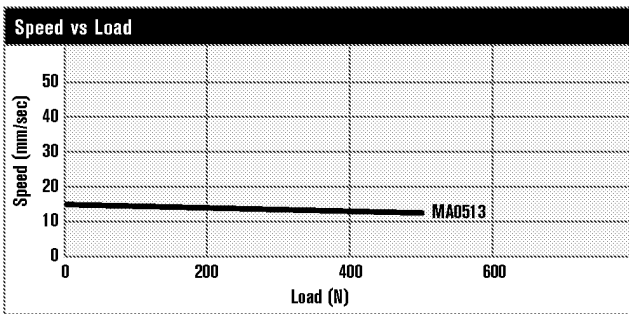

2-2 MA1527 & MA3507 Drawing and Charts

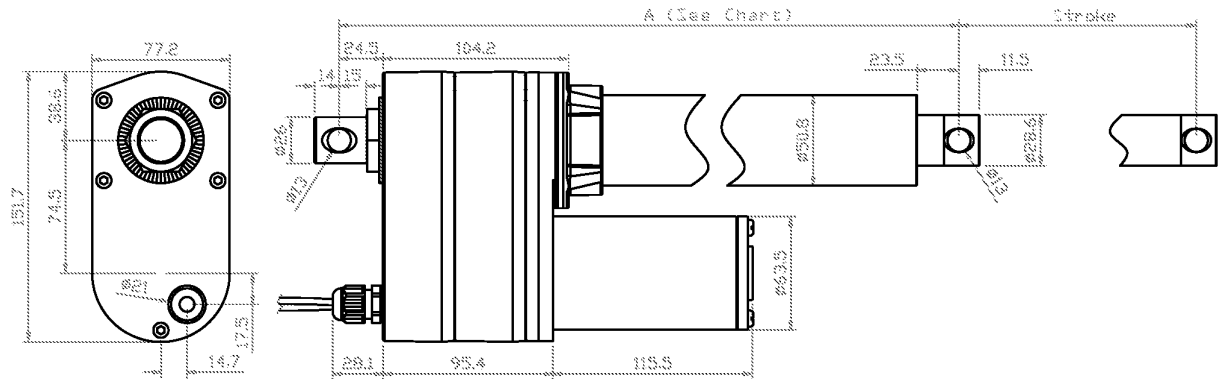

Drawing dimensions shown in millimeters

Part number	Capacity N (lb)	Stroke mm (in)	Travel speed mm/sec (in/min)	Retracted (A) Mm (in)
MA1527B1115	1500 (337)	153 (6.0)	27 (64)	410 (16.1)
MA1527B1130	1500 (337)	305 (12.0)	27 (64)	613 (24.1)
MA1527B1145	1500 (337)	457 (18.0)	27 (64)	765 (30.1)
MA3507B1115	3500 (787)	153 (6.0)	7 (17)	410 (16.1)
MA3507B1130	3500 (787)	305 (12.0)	7 (17)	613 (24.1)
MA3507B1145	3500 (787)	457 (18.0)	7 (17)	765 (30.1)

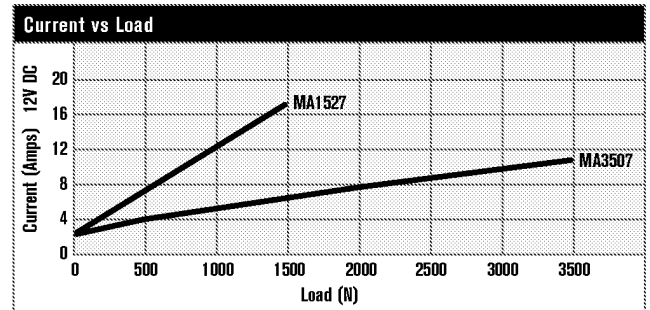
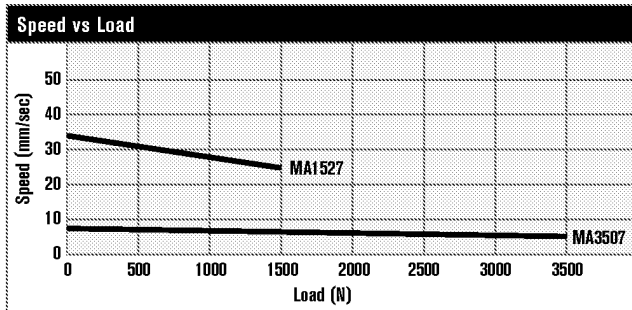

Section III Order information

3-1 Part Number Description

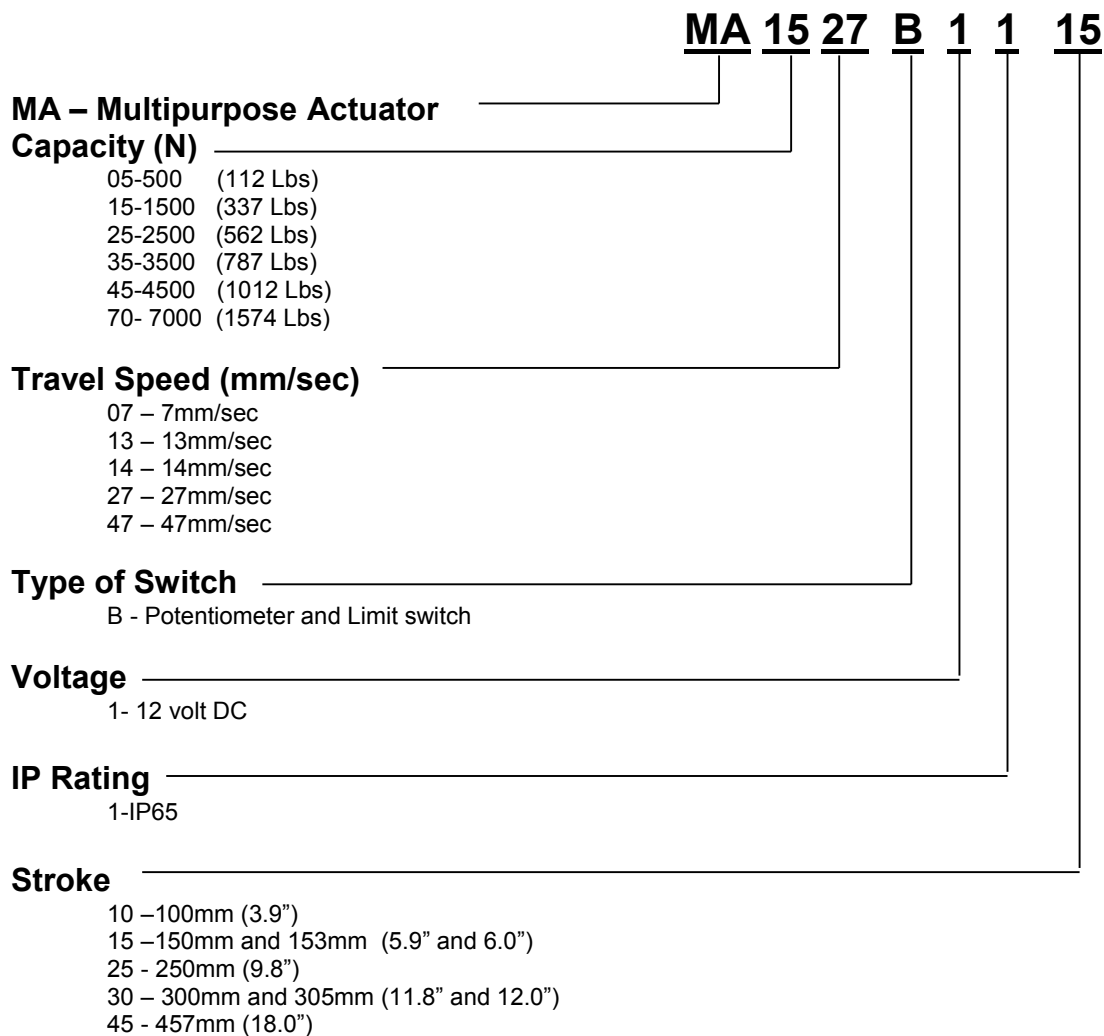

3-2 Serial Number

The serial number is etched on the front of each actuator, just below the Joyce Logo. Use the serial number to positively identify the actuator when reordering or when communicating with Joyce/Dayton.

Joyce/Dayton Corporation
P.O. Box 1630
Dayton, Ohio 45401
Phone (800) 523-5204 (U.S. & Canada); (937) 294-6261 Fax (937) 297-7173
www.joycedayton.com E-mail: sales.jacks@joycedayton.com

FB0254 – 2/11