



## JOYCE/DAYTON CORP.

ACME SCREW ELECTRIC CYLINDERS  
OPERATION AND MAINTENANCE MANUAL – FB0197  
[sales@joycedayton.com](mailto:sales@joycedayton.com)  
937-294-6261

### Acme Screw Electric Cylinders



*The product described in this catalog is for industrial use only. It may not be used to lift or support people without prior written approval from the Joyce/Dayton Corp. Recommendations in this manual for installation, operation and maintenance must be followed to ensure safe use. All persons responsible for the installation and use of Joyce Acme Screw Electric Cylinders must be familiar with the contents of this manual. Customer is responsible for providing travel stops.*

# TABLE OF CONTENTS

## SECTION I – GENERAL INFORMATION

1-1 Contact Joyce/Dayton .....	2
1-2 Purpose and Scope .....	2
1-3 Receipt of Product .....	2
1-4 Warranty.....	3
1-5 Precautions of Use and Installation .....	3
1-6 General Installation Instructions.....	3

## SECTION II – MAINTENANCE

2-1 Lubrication.....	4
2-2 Repair Parts.....	5
2-3 Disassembly of Electric Cylinders (ECA).....	5

## SECTION III – VIEWS & PARTS LIST

3-1 Cutaway View .....	6
3-2 Parts List .....	7
3-3 Specifications .....	8
3-4 Serial Number and Maintenance .....	10

## SECTION I GENERAL INFORMATION

### 1-1 CONTACT JOYCE/DAYTON CORP.

Joyce/Dayton Corp.  
P.O. Box 1630  
Dayton, OH 45401  
(800) 523-5204 (US and Canada only)  
(937) 294-6261 Phone (937) 297-7173 Fax  
Email : sales@joycedayton.com  
Website: [www.joycedayton.com](http://www.joycedayton.com)

### 1-2 PURPOSE AND SCOPE

This manual provides installation, operation and maintenance instruction for standard Joyce/Dayton Acme Screw Electric Cylinders. Although this manual covers the standard electric cylinders and most variations there may be some units that vary significantly from this manual. For special electric cylinders, not covered, please contact Joyce/Dayton Corp. for assistance.

### 1-3 RECEIPT OF PRODUCT

All equipment should be immediately inspected upon receipt for any damage and to verify correct product and quantities. Any problems should be reported to Joyce/Dayton Corp. and the freight carrier as soon as possible. Products returned without a *Return Materials Authorization (RMA)* form will not be accepted.

## 1-4 WARRANTY

Seller warrants its products to be free from defects in material and workmanship under normal and proper use in accordance with instruction of seller for a period of one year from the date of shipment to buyer. Seller's liability under such warranty or in connection with any other claim relating to the products shall be limited to the repair, or at seller's option, the replacement or refund of the purchase price, of any products or parts or components thereof which are returned to seller freight prepaid and which are defective in material or workmanship. Products or parts or components thereof, which are repaired or replaced by seller, will be returned to buyer freight collect. This warranty is not intended to cover consumer products, as defined in the Magnuson-Moss Warranty-Federal Trade Commission Improvement Act, 15 U. S. C. Sections 2301-12, which are purchased by buyer for purposes other than resale. If buyer is not intending to resell the products, and if the products are consumer products as defined in the Magnuson-Moss Act, the foregoing warranty, but not the limitation of seller's liability, shall be null and void. EXCEPT AS EXPRESSLY STATED ABOVE, SELLER MAKES NO WARRANTY, EXPRESS OR IMPLIED, WHETHER OF MERCHANTABILITY OR FITNESS FOR ANY PARTICULAR PURPOSE OR USE OR OTHERWISE, ON THE PRODUCTS, OR ON ANY PARTS OR LABOR FURNISHED DURING THE SALE, DELIVERY OR SERVICING OF THE PRODUCTS.

## 1-5 PRECAUTIONS OF USE AND INSTALLATION

1. Mechanical stops, if provided on the Electric Cylinders, (ECA), are only auxiliary devices to limit the travel of the lifting screw. Engaging a mechanical stop during electric cylinder operation can cause damage to the internal mechanism.
2. Travel can be limited using optional limit switches. The customer is responsible for setting these limit switches. In most applications, factory or manufacturer-assisted installation is not required. However, it is necessary that appropriate, qualified personnel perform the installation of Joyce/Dayton products.
3. Joyce/Dayton Electric Cylinders, (ECA), are not rated for shock-loading, extreme vibration or critical speed conditions. It is the responsibility of the user to ensure these conditions are not imposed on the actuator or the power transmission equipment. Contact Joyce/Dayton for technical assistance.
4. In the event that service or maintenance is required, the load must be secured or removed before any work can begin.
5. The Electric Cylinder (ECA) can be mounted and operated in any orientation. When used in a horizontal position, the worm should be mounted parallel with the horizon and below the gear to ensure proper lubrication. In addition, the length of allowable rise may differ for vertical and horizontal applications. Check the catalog and this manual for allowable rises.
6. **Standard Electric Cylinders, (ECA) have vents in the protection tube (outer tube). Additional holes will be plugged. Properly plug or vent holes to prevent dirt or moisture from contaminating the actuator.**
7. Never allow the Electric Cylinder to retract beyond the minimum closed position or extend beyond the maximum open position, as damage to the unit can occur.
8. External temperature may exceed 230 Degrees F. near maximum duty cycle. Use caution to prevent personal injury.
9. **Do not use in applications where Electric Cylinder can be jammed against an immovable object.**
10. A brake motor is required on Acme Screw Electric Cylinders that have efficiencies greater than or equal to 30%. This prevents the load from drifting when power is off.
11. Acme screw electric cylinders are not suitable for duty cycles greater than 25%.

## 1-6 GENERAL INSTALLATION INSTRUCTIONS

1. Ensure that all personnel who will service or operate equipment are familiar with its use and limitations.
2. Secure or remove the load before any installation procedures begin.
3. Be certain the rating of the Electric Cylinder (ECA) meets or exceeds the load.
4. The Electric Cylinder (ECA) must be mounted on a rigid structure which is sufficient to support the maximum possible load. The structure must be rigid. An under-designed structure could lead to premature wear or failure.
5. Drive shaft alignment is critical. Misalignment will cause reversing stresses in rotating members and will lead to fatigue failure. Correct coupling specification is critical.
6. In systems with shafting, miter boxes, etc., confirm that the shafts and jacks operate without binding or excessive force before powered drive devices are engaged.

7. When fastening the load to an Electric Cylinder, make sure the actuator is in the retracted position. This positions the load accurately with respect to the lifting screw centerline. Never pull the translating tube to one side to make connection with your structure. Fully extend the Electric Cylinder to make sure the load is aligned with the translating tube.
8. All Electric Cylinders are to be mounted with S.A.E. Grade 8 bolts or equivalent.
9. Torque the mounting bolts in a systematic pattern to avoid damage to the actuator.
10. Shaft and coupling guards are the responsibility of the user.
11. Optional limit switches, which may be furnished with the Electric Cylinder, are NOT pre-set. They require field adjustment before use.

## SECTION II

### MAINTENANCE

#### 2-1 LUBRICATION

##### Electric Cylinder

1. Electric Cylinders are lubricated before leaving the factory.
2. Do not operate Electric Cylinders without lubrication.
3. For normal operation, Electric Cylinders should be greased at least once per month. Under extended use, grease twice monthly or as conditions dictate. Grease with Mobil XHP 461 through the fittings on the Housing (1) and on the protection tube (20). This is a No. 1 Consistency Grease. It is the responsibility of the user to maintain sufficient lubrication to the electric Cylinder.
4. The products listed below are recommended by the lubricant manufacturers to meet the requirements for normal operation. The listing of brand names is solely for the convenience of users of Joyce equipment and their lubricant suppliers; it does not constitute any endorsement. Joyce/Dayton assumes no responsibilities for the quality, performance or availability of any listed products

Company	Brand Name	Electric Cylinder Component
Exxon Mobil	Mobilgrease XHP 461	Housing
Exxon Mobil	Mobilith SHC PM 460	Housing
Exxon Mobil	Mobilith SHC 221	Housing
Exxon Mobil	Mobilgrease XHP 461	Lifting screw and Tube

5. For operation above 250° or for extreme loading, consult the Engineering Department of Joyce/Dayton Corp. ([sales@joycedayton.com](mailto:sales@joycedayton.com)).

##### Gear Reducer (Option)

1. Standard ComDRIVE Electric Cylinder Gear Reducers are lubricated with AGMA 7 compounded oil (ISO Grade 460) before leaving the factory.
2. The products listed are recommended by the lubricant manufacturers to meet the requirements for normal operation. The listing of brand names is solely for the convenience of users of Joyce/Dayton equipment and their lubricant suppliers; it does not constitute any endorsement. Joyce/Dayton assumes no responsibilities for the quality, performance or availability of any listed products.

Company	Brand Name	ComDRIVE Electric Cylinder component
Mobil Oil	Mobil 600W Cylinder Oil	Gear reducer
Mobil Oil	Mobil 85W100	Gear Reducer
Mobil Oil	Mobil SHC 634 (synthetic)	Gear Reducer

3. Synthetic Lubricants are recommended for severe service applications. These lubricants offer more stable viscosity and temperature properties. They have a longer service life and may require less frequent lubrication

changes. They also decrease friction and wear on the gear reducer and may increase the life of the gear reducer.

4. This synthetic lubrication is also compatible with nitrile seal material as well as with alloy bronze gear material.

## 2-2 REPAIR PARTS

Obtain repair parts by contacting Joyce/Dayton Customer Service at (800) 523-5204, (937) 294-6261, (937) 297-7371 (facsimile), sales@joycedayton.com, or call your local sales representative. When ordering repair parts, please supply the serial number (located on the jack nameplate).

Recommended repair parts for rebuild or spares. Refer to Section 3-1 Exploded view and Section 3-2 Parts List.

- A. (2) Thrust Bearing
- B. (1) Worm Gear Nut
- C. (1) Worm
- D. (2) Worm Shaft Bearing
- E. (2) Worm Shaft Seal
- F. (1) Translating Tube and Screw Assembly
- G. (2) Bushings
- H. (1) Wiper Seal
- I. (1) Motor (Direct Drive or ComDRIVE option)
- J. (1) Gear reducer (ComDRIVE option)
- K. (1) Motor mount (Direct Drive option)

## 2-3 DISASSEMBLY OF ELECTRIC CYLINDER

Before beginning to disassemble these units make sure the load has been removed and secured according to best practice standards for safety.

### **Direct Drive Option and ComDrive Option**

1. Motors supplied with Direct Drive and ComDRIVE units are not user serviceable.
2. Loosen the bolts attaching the motor to the jack or to the gear reducer and remove the motor.
3. The gear reducer on ComDRIVE units must also be removed before the electric cylinder can be disassembled.

### **Limit Switch, Encoder, or Potentiometer Option**

4. Loosen the bolts holding the limit switch, encoder, or potentiometer and remove from their mounting bracket.
5. Loosen the bolts attaching the mounting bracket to the electric cylinder and remove

### **Disassembly of Acme Screw ComDrive (ECA)**

6. Loosen the hex head screws on the worm bearing caps or remove the mounting adapters described above.
7. Remove the worm bearings and remove the worm shaft through the end of the sleeve. This may also be removed after the Translating Tube and Screw Assembly is removed later in the process.
8. Extend the translating tube assembly a few inches. This positions the components to be more easily disassembled.
9. Loosen the setscrews at the base of the protection tube.
10. Unthread the protection tube and pull it off over the end of the translating tube assembly.
11. Loosen the set screws that secure the sleeve cap. Unthread the sleeve cap and remove it.
12. This will allow the translating tube assembly along with several internal components to be pulled up out of the sleeve.
13. Remove the retaining ring located at the base of this assembly and remove the key.
14. Remove any portion of the lower bearing that may be attached to the worm gear nut.
15. Unthread the worm gear nut from the lifting screw.
16. The upper thrust bearing can now be separated from the worm gear nut along with the seal.
17. Remove the grease from the cavity and inspect parts for damage or wear.
18. Assemble replacement components by carefully reversing the disassembly process.

# SECTION III VIEWS AND PARTS LIST

## 3-1 CUTAWAY VIEW

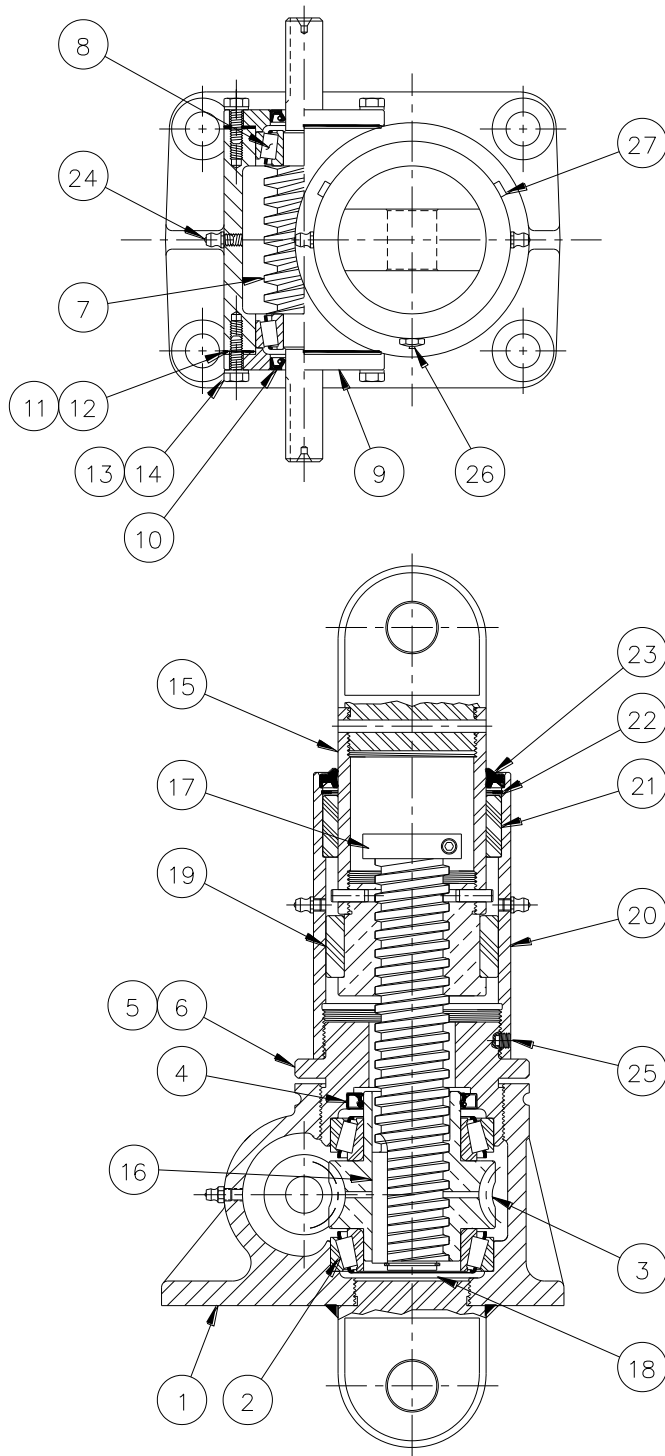

### 3-2 PARTS LIST – ACME SCREW ELECTRIC CYLINDER (ECA)

Item		Item	
1	Electric Cylinder Sleeve (1)		With Motor Mount (not shown)
2	Thrust Bearing (2)		Motor Mount Bracket (1)
3	Worm Gear Nut (1)		Hex Head Screw (4)
4	Seal (1)		Lock Washer (4)
5	Sleeve Cap (1)		Hex Head Screw (4)
6	Set Screw (4)		Pipe Plug (2)
7	Worm (1)		Coupling (1)
8	Worm Shaft Bearing (2)		Key (1)
9	Bearing Cap (1)		Motor (1)
10	Worm Shaft Seal (2)		
11	Shim, Blue (4)		
12	Shim, Clear (2)		
13	Hex Head Screw (6)		<b>With ComDRIVE (not shown)</b>
14	Lock Washer (6)		Reducer Mounting Adapter (1)
15	Translating Tube and Screw Assembly (1)		Gear Reducer (1)
16	Key (1)		Key (1)
17	Stop (1)		Hex Head Screw (4)
18	Retaining Ring (1)		Lock Washer (12)
19	Bushing, Translating Tube (1)		Motor (1)
20	Protection Tube (1)		Woodruff Key (1)
21	Bushing, Protection Tube (1)		Hex Head Screw (6)
22	Retaining Ring (1)		Lock Washer (4)
23	Double Lip Wiper (1)		Hex Head Screw (4)
24	Grease fitting (1)		Shim, Yellow (2)
25	Set Screw (2)		Shim, Clear (6)
26	Air Vent (1)		Shim, Blue (6)
27	Pipe Plug (4)		Worm Shaft Seal (1)
			Worm Shaft Bearing (1)
	<b>OTHER OPTIONS (NOT SHOWN)</b>		<b>LIMIT SWITCH COMPONENTS (NOT SHOWN)</b>
	SLEEVE WITH ROTATED CLEVIS (1)		Roll Pin (1)
	Plug (1)		Optional Limit Switch Adapter (1)
	Flanged Sleeve (1)		Optional Limit switch (1)
	CLEVIS PIN (1)		Screw (4)
	Female Rod Clevis (1)		Flat Washer (4)
	Male Clevis Rod End (1)		Screw (1)
	Dowel Pin (1)		
	Set Screw (2)		

### 3-3 SPECIFICATIONS

Model Number	ECAL242.5	ECAH62.5 ECAH122.5 ECAH242.5	ECAL63 ECAL123 ECAL243	ECAL65 ECAL245	ECAM65 ECAM125 ECAM245	ECAH65 ECAH125 ECAH245
Static Capacity	2.5 TON	2.5 TON	3 TON	5 TON	5 TON	5 TON
Lifting Screw Diameter (inches)	1	1	1 1/4	1 1/2	1 1/2	1 1/2
Thread Pitch/ Lead (inches)	.25	.25/ .50	.25	.25	.375	.25 / .50
Worm Gear Ratio	24:1	6:1 12:1 24:1	6:1 12:1 24:1	6:1 24:1	6:1 12:1 24:1	6:1 12:1 24:1
Worm Shaft Turns for 1" Travel	96	12 24 48	24 48 96	24 96	16 32 64	12 24 48
Tare Torque (inch/Lbs.)	6	8 7 6	9 8 7	15 12	15 13 12	15 13 12
Starting Torque (Inch/lbs.)	.018W*	.056W* .035W* .025W*	.048W* .030W* .021W*	.057W* .026W*	.065W* .041W* .030W*	.073W* .046W* .033W*
Operating Torque (inch lbs.) @ Worm RPM	.010W** @ 500 RPM	.040W* .023W* .014W* @ 500 RPM	.033W* .018W* .011W* @ 500 RPM	.039W* .014W* @ 300 RPM	.045W* .025W* .016W* @ 300 RPM	.051W* .029W* .018W* @ 300 RPM
Translating Tube Torque * (inch lbs.)	.098 W*	.140 W*	.114W	.130 W*	.151 W*	.171W*
Base Weight ( lbs)	24	24	26	50	50	50
Add to Basic Jack Weight (lbs.) for each Additional 1" of Travel	1.5	1.5	1.9	2.3	2.3	2.3
Max. Vertical Rise	28"	28"	48"	59"	63"	59
Max. Horizontal Rise	21"	21"	36"	44"	47"	44



### 3-3 SPECIFICATIONS (CONTINUED)

Model Number	ECAL810 ECAL2410	ECAM810 ECAM2410	ECAH810 ECAH2410	ECAL820 ECAL2420	ECAM820 ECAM2420	ECAH820 ECAH2420
Static Capacity	10 TON	10 TON	10 TON	20 TON	20 TON	20 TON
Lifting Screw Diameter (inches)	2	2	2	2 1/2	2 1/2	2 1/2
Thread Pitch/ Lead (inches)	.25	.50	.33 / .66	.25	.50	.375/.75
Worm Gear Ratio	8:1 24:1	8:1 24:1	8:1 24:1	8:1 24:1	8:1 24:1	8:1 24:1
Worm Shaft Turns for 1" Travel	32 96	16 48	12 36	32 96	16 48	10.67 32
Tare Torque (inch/Lbs.)	30 25	30 25	30 25	60 40	60 40	60 40
Starting Torque (Inch/lbs.)	.052W* .026W*	.061W* .031W*	.070W* .035W*	.066W* .035W *	.075W* .039W*	.088W* .046W*
Operating Torque † (inch lbs.) @ Worm RPM	.036W* .016W* @ 200 RPM	.044W* .019W* @ 200 RPM	.051W* .022W* @ 200 RPM	.044W* .019W* @ 200 RPM	.052W* .022W* @ 200 RPM	.062W* .027W* @ 200 RPM
Translating Tube Torque * (inch lbs.)	.162W	.195W*	.228W*	.194W*	.227W*	.273W*
Base Weight ( lbs)	64	64	64	124	124	124
Add to Basic Jack Weight (lbs.) for each Additional 1" of Travel	2.8	2.6	2.7	4.9	4.7	4.8
Max. Vertical Rise	84"	60"	76"	100"	78"	88"
Max. Horizontal Rise	63"	45"	57"	75"	58"	66"

W\* = Load in pounds

Tare Torque: The initial torque needed to overcome seal and normal assembly drag. This value must be added to starting torque or operating torque values.

Starting Torque: Torque value required to start moving a given load (dissipates to operating torque value once the load begins moving).

Operating Torque: Torque required to continuously raise a given load at the input RPM listed.

Translating Tube Torque: Torque required to resist the tube rotation.

### 3-4 SERIAL NUMBER & MAINTENANCE

Date	Maintenance Performed	Initials

Joyce Dayton Serial Number Tag



Contact Joyce Dayton Corporation and provide the serial number to obtain the product information needed for maintenance, repair and reorder.

**Joyce/Dayton Corp**  
P.O. Box 1630  
Dayton, Ohio 45401  
Phone (800) 523-5204 (U.S. & Canada); (937) 294-6261 Fax (937) 297-7173  
[www.joycedayton.com](http://www.joycedayton.com) E-mail: [sales@joycedayton.com](mailto:sales@joycedayton.com)